8. Business Process Modeling

Abdus Sattar

Assistant Professor

Department of Computer Science and Engineering

Daffodil International University

Email: abdus.cse@diu.edu.bd



Discussion Topics

- Business process modeling(BMP)
- Notation defining workflows
- Some rules for creating BPN
- BPM example and practicing
- Why does BPM uses?
- Integrating Requirements and Business Process Models in BPM Projects(Online Materials)

Business Process Model(BPM)

- ❑ Business process modeling is the graphical representation of a company's business processes or workflows, as a means of identifying potential improvements.
- ❑ Business process modelling represents:
 - Business activities,
 - Information flow and,
 - Decision logic in business processes.

Elements of BPS



Start Event

A Start Event indicates where a particular process will start.



Intermediate Event

Intermediate Events occur between a Start Event and an End Event. It will affect the flow of the process, but will not start or (directly) terminate the process.



End Event

An End Event indicates where a process will end.

Elements of BPS



Sequence Flow



Message Flow



Association

Elements of BPS

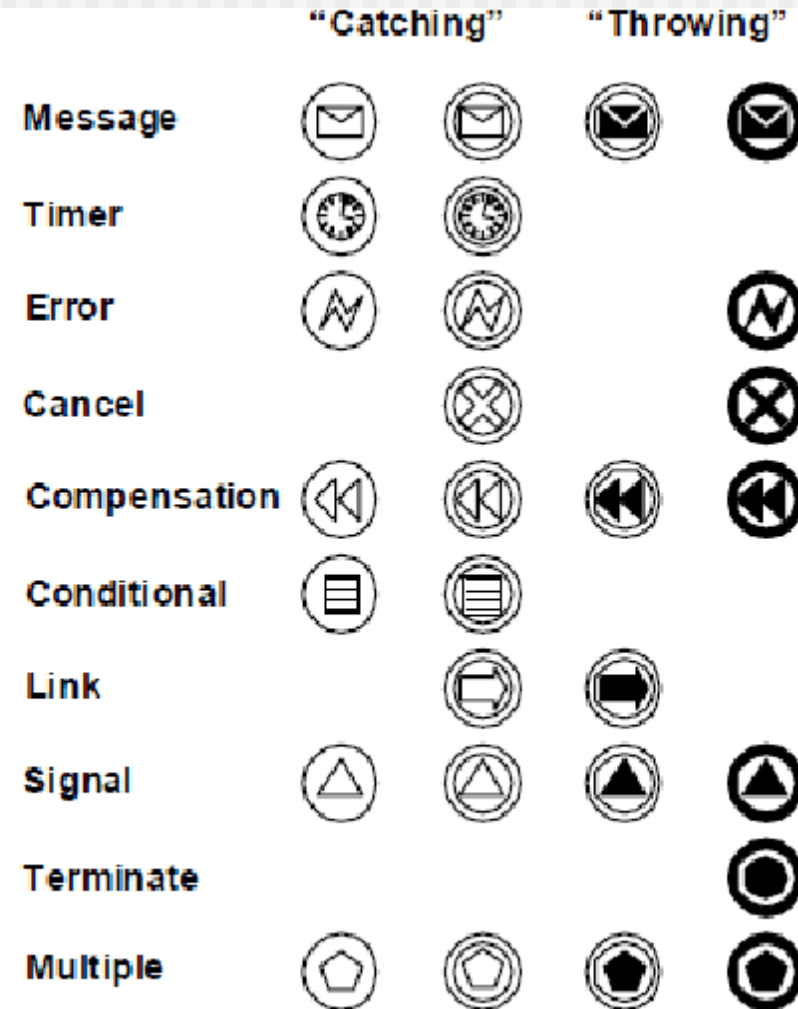
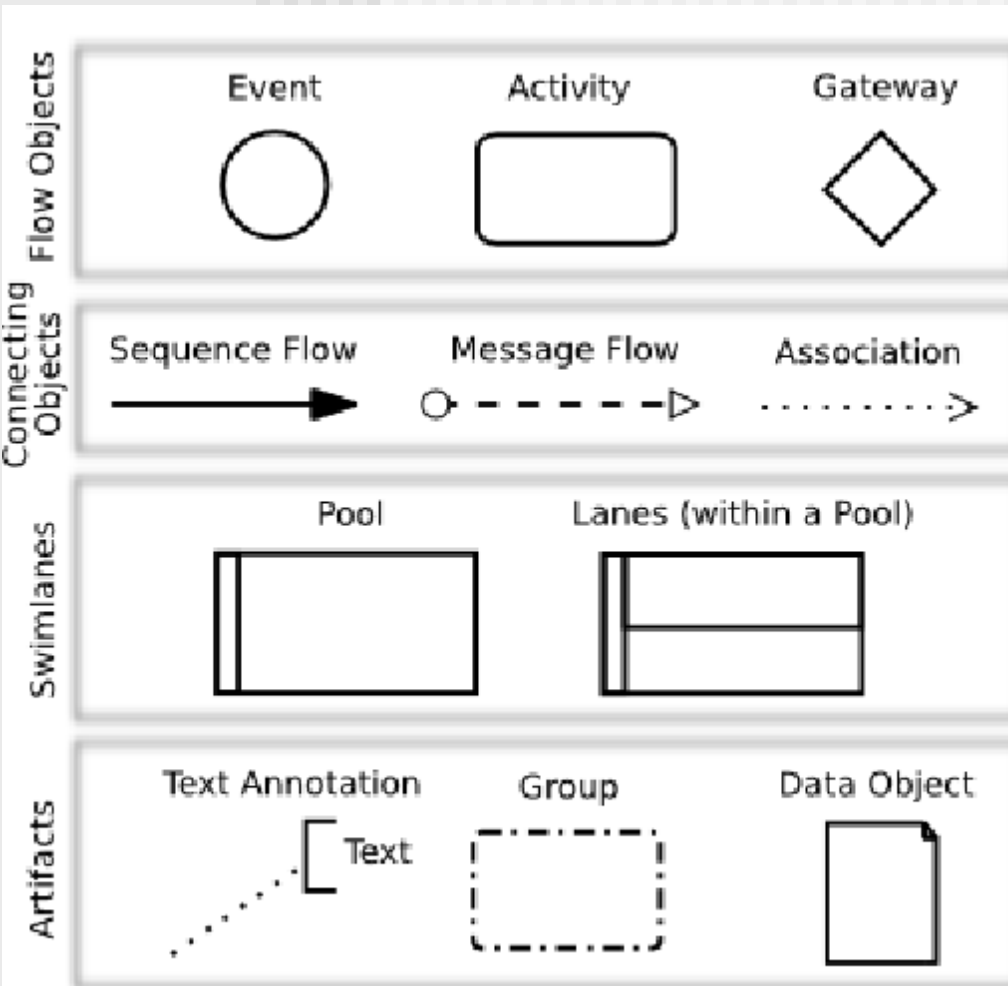

Gateway Types

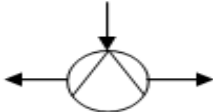
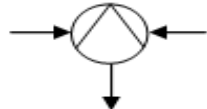
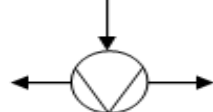
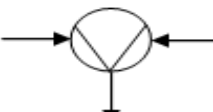
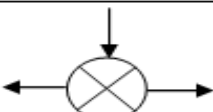
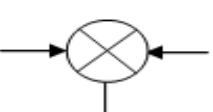
Konnektors:	AND	Split	
		Join	
	OR	Split	
		Join	
	XOR	Split	
		Join	

Logical Connectors

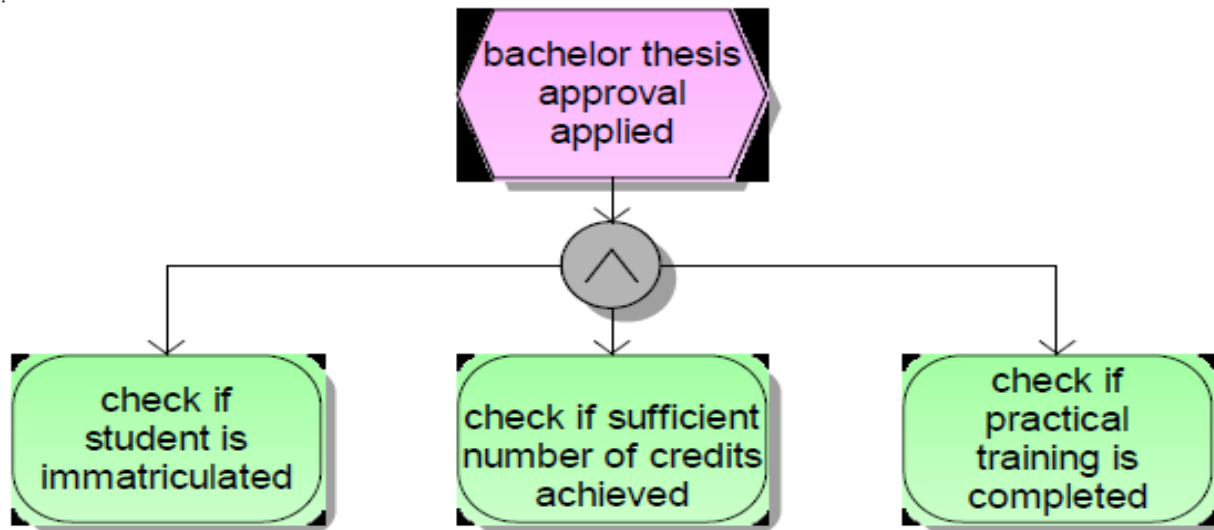

 AND - Function

After the event, all the functions are started

Different Types of "OR"

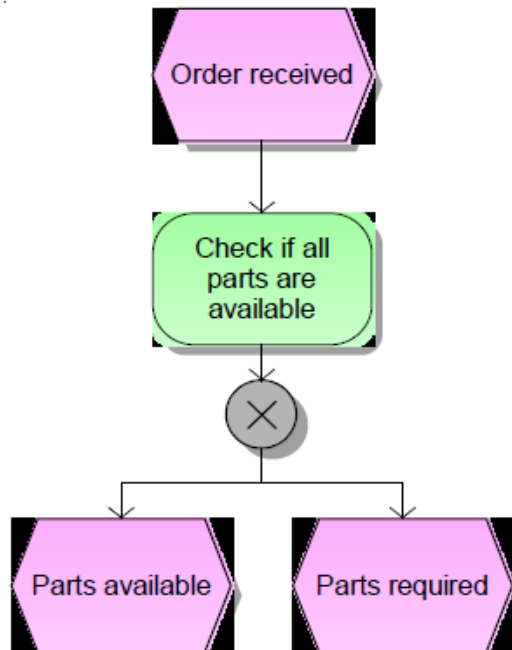

 Exclusive OR - Function
After the Function just one event is occurring

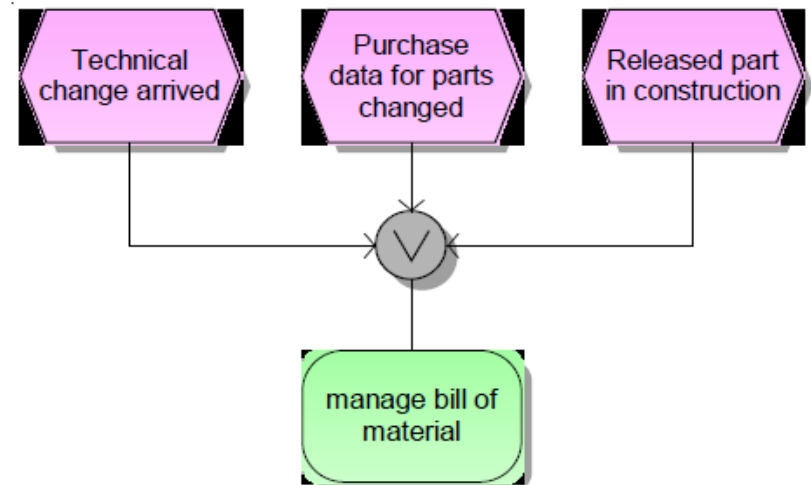

 OR - Function
Function can only be started if one or more events have occurred

Some rules for EPCs

- ❑ at least one function
- ❑ at least one start event
- ❑ at least one end event
- ❑ each function is preceded and followed by an event
- ❑ an event is preceded and followed by a function, except the start and end events
- ❑ each event and function has, at most, one ingoing and one outgoing flow
- ❑ splits and joins are realised via connectors
- ❑ an OR or XOR split cannot be invoked by an event (events cannot decide anything)

Business Process Model for Payment Process

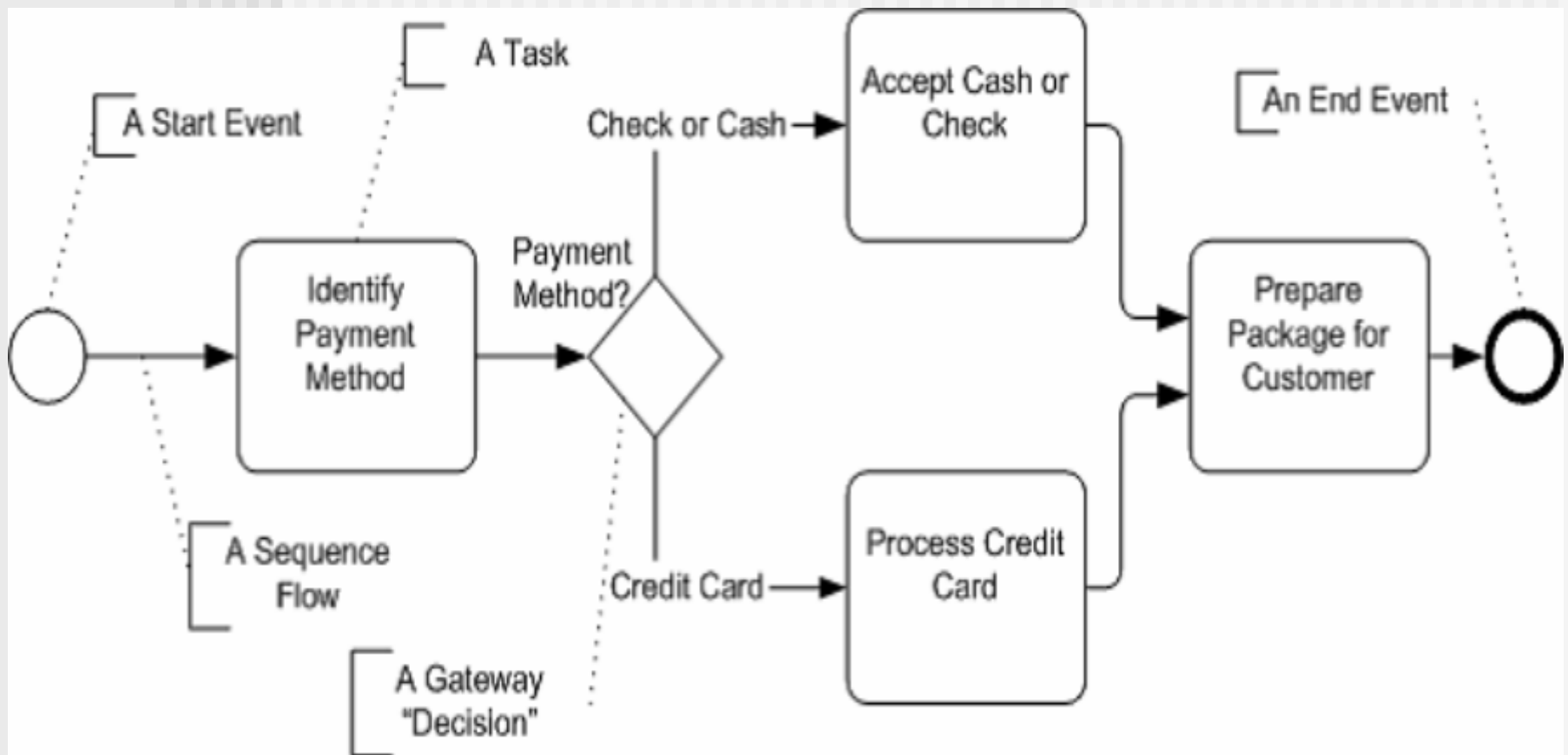

BPM for Ordering request

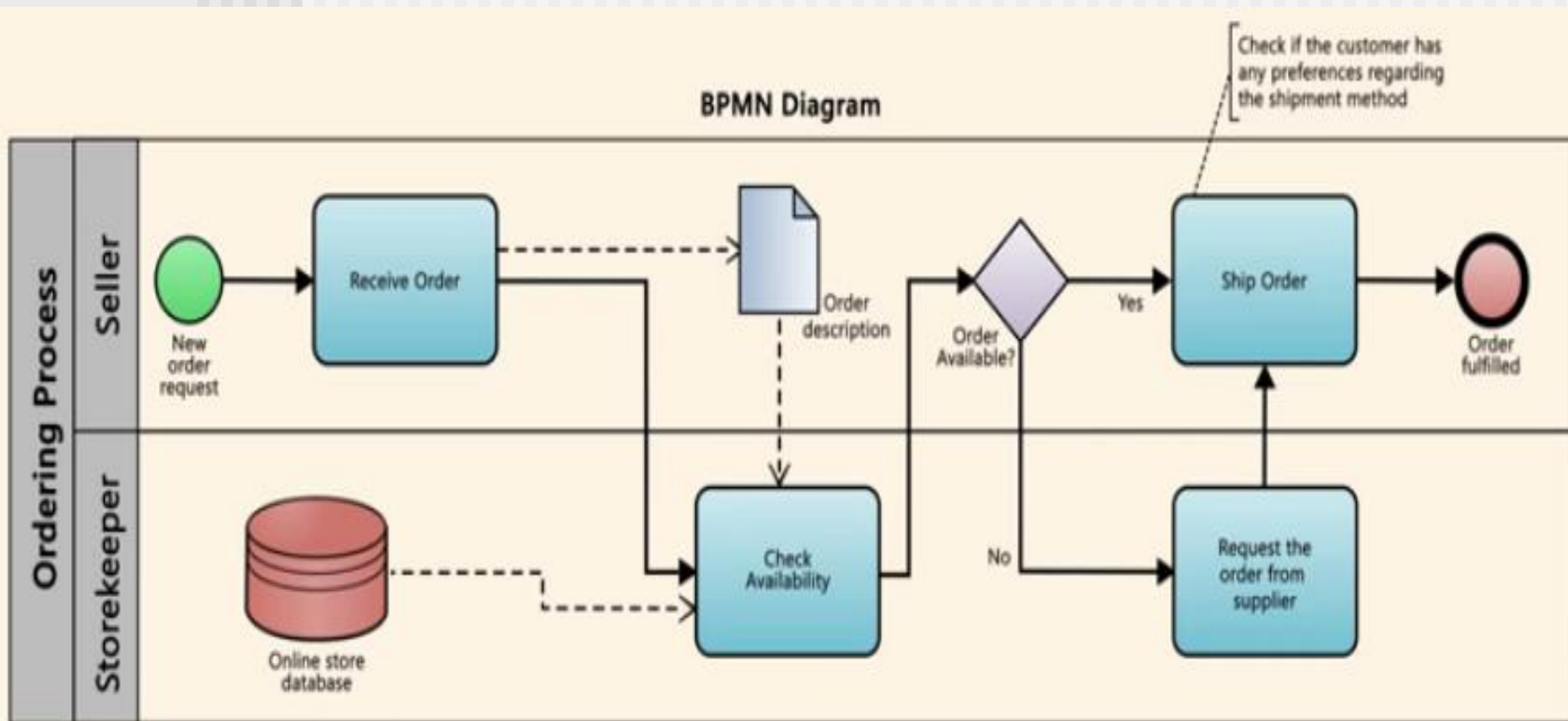

A Business Process Modeled Using BPN Notation

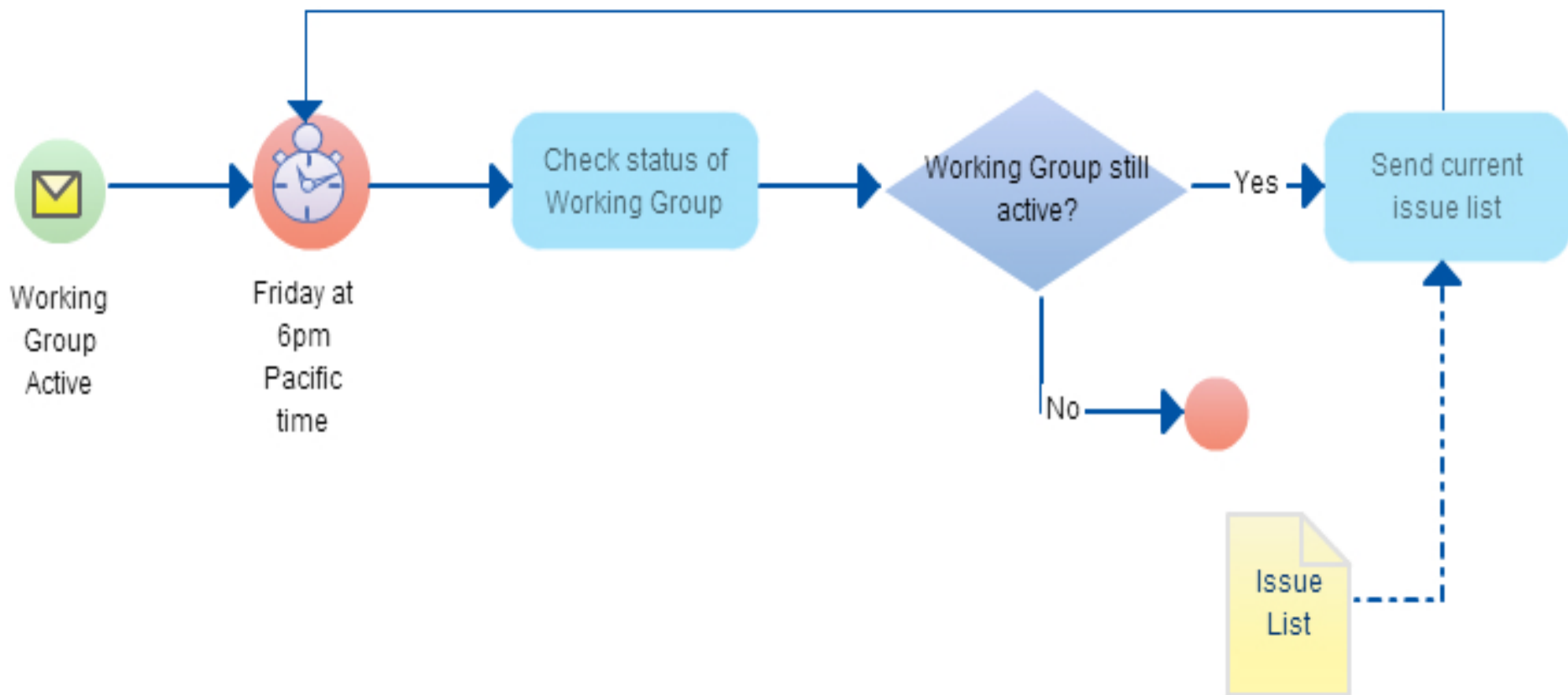

Business Process Model for Book Requisition Request

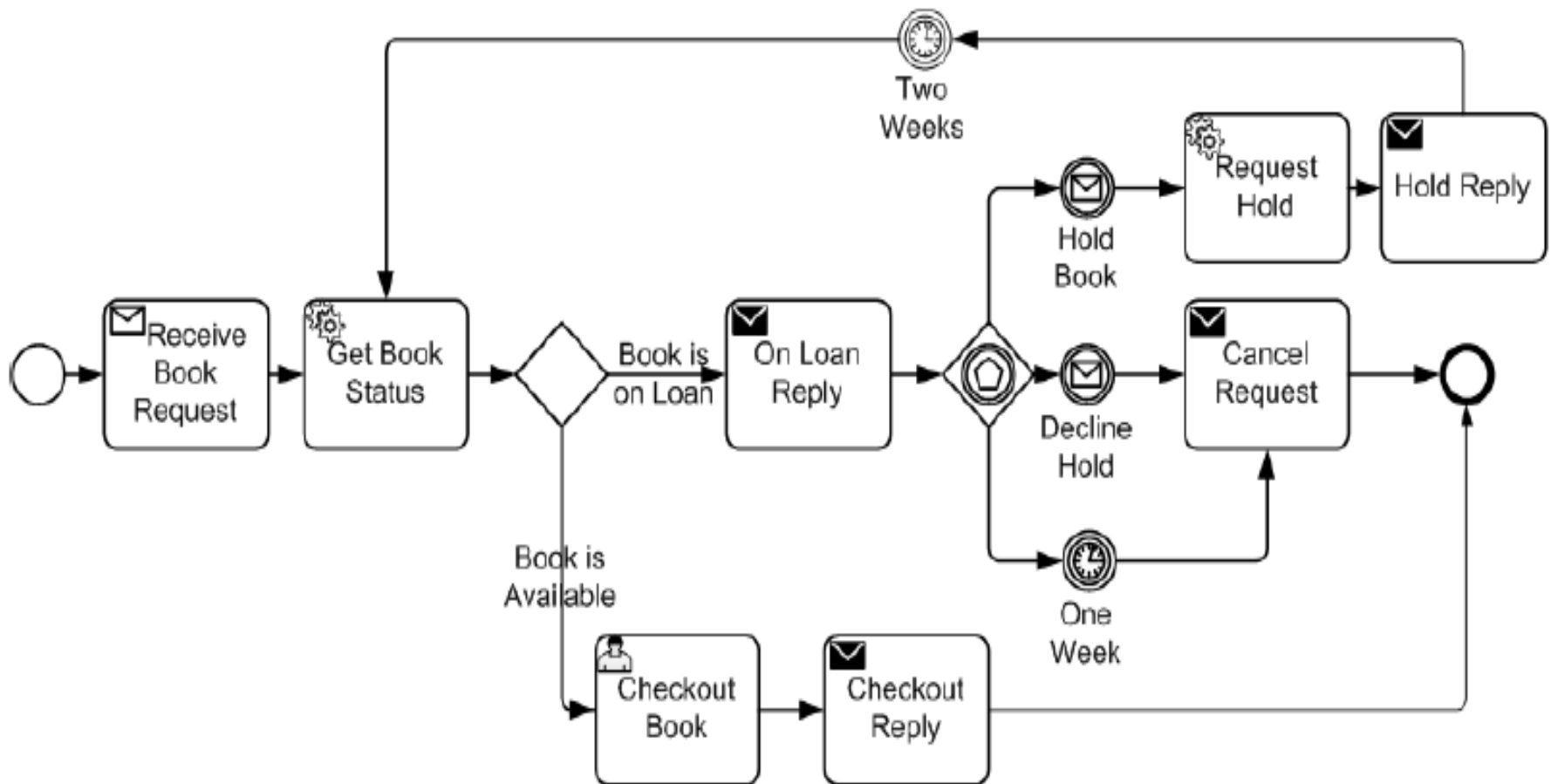

Business Process Model for product order from ebay

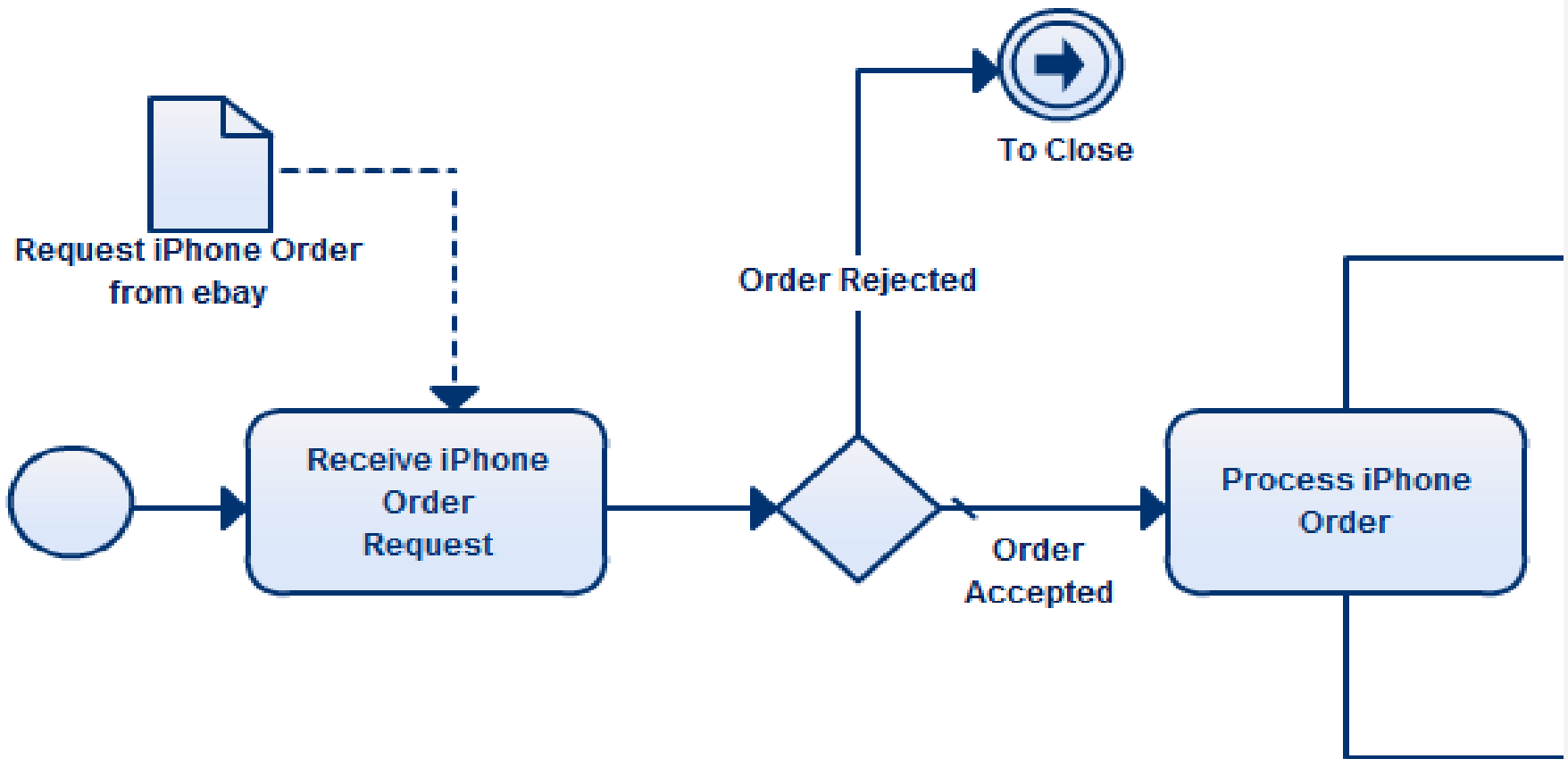

Why Use Business Process Modeling

- 1. Align Operations with Business Strategy**
- 2. Improve Process Communication**
- 3. Increase Control and Consistency**
- 4. Improve Operational Efficiencies**
- 5. Gain Competitive Advantage**