

Common Unbalanced Network Faults

- **Single-line-to-ground faults**
- **Double-line-to-ground faults**
- **Line-to-line faults**

Single Line to Ground Fault

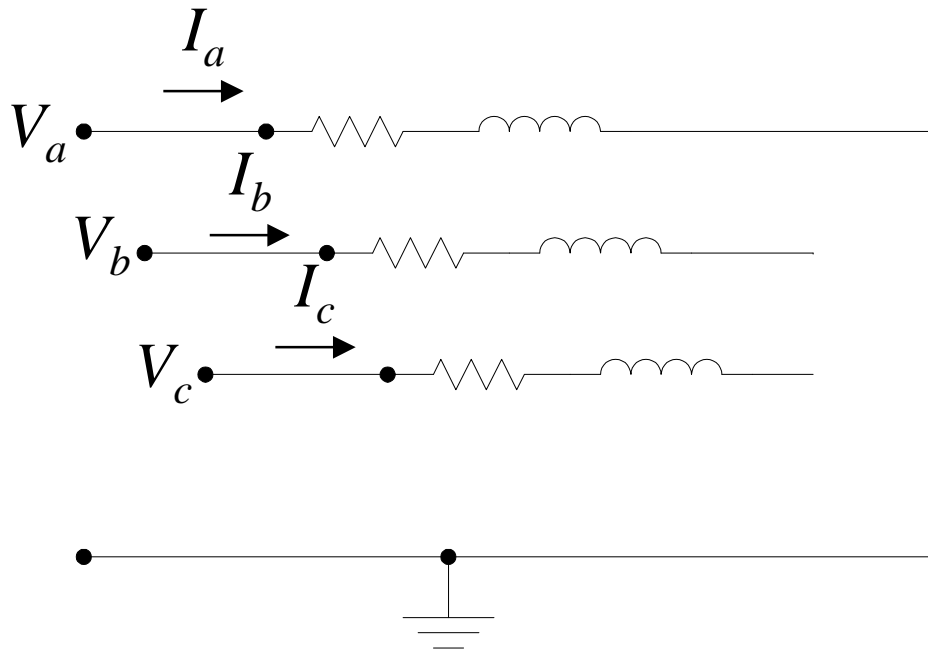

$$V_a = 0$$

$$I_f = I_a$$

$$I_b = I_c = 0$$

$$\begin{bmatrix} I_{a0} \\ I_{a1} \\ I_{a2} \end{bmatrix} = \frac{1}{3} \begin{bmatrix} 1 & 1 & 1 \\ 1 & a & a^2 \\ 1 & a^2 & a \end{bmatrix} \begin{bmatrix} I_a \\ 0 \\ 0 \end{bmatrix}$$

$$I_{a0} = I_{a1} = I_{a2} = \frac{1}{3} I_a$$

$$V_a = V_{a0} + V_{a1} + V_{a2} = 0$$

Single Line to Ground Fault

$$\begin{aligned}V_a &= E_a - Z_a I_a = 0 \\&= E_a - A (Z_{012} I_{012}) \\&= E_a - (Z_{a0} I_{a0} + Z_{a1} I_{a1} + Z_{a2} I_{a2}) \\&= E_a - (Z_{a0} + Z_{a1} + Z_{a2}) I_{a0}\end{aligned}$$

$$I_{a0} = \frac{E_a}{(Z_{a0} + Z_{a1} + Z_{a2})}$$

$$I_{a0} = I_{a1} = I_{a2}$$

$$I_f = 3 I_{a0}$$

Network Diagram

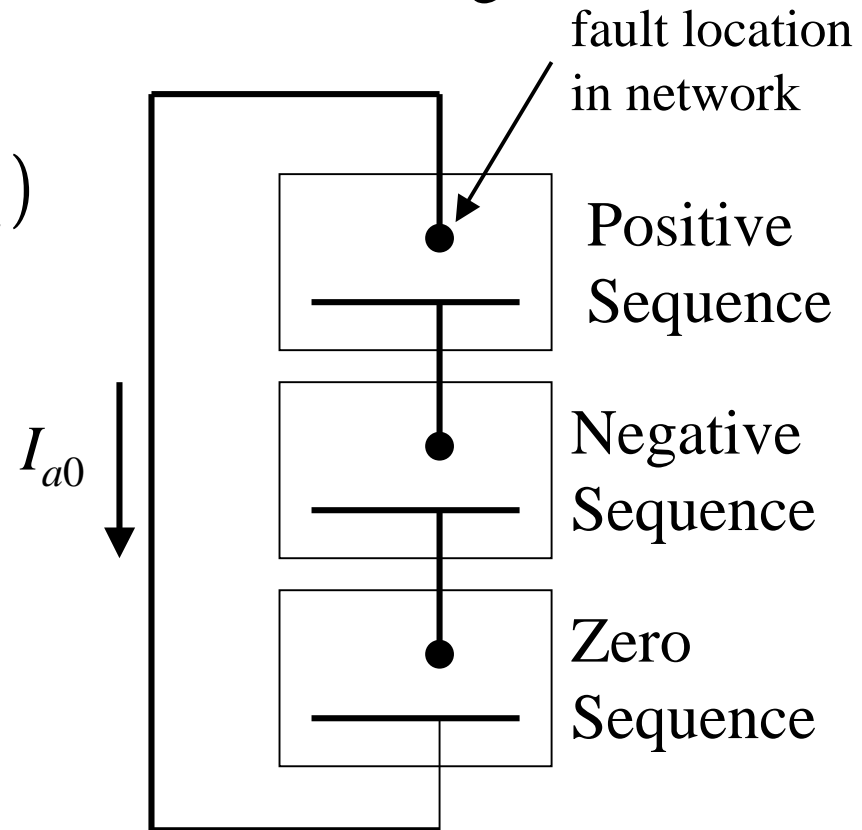

Double Line to Ground Fault

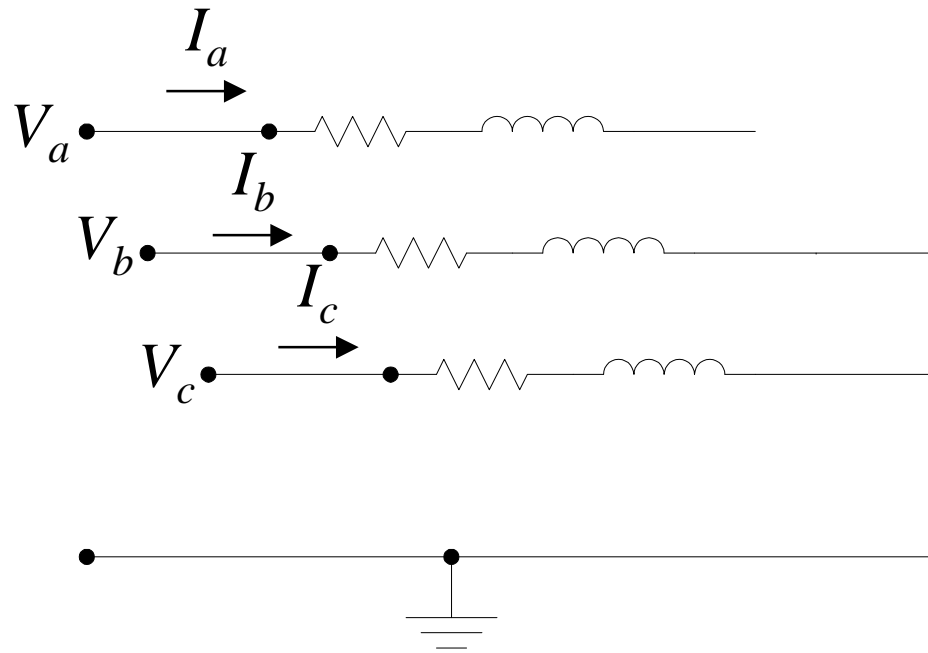

$$V_b = 0$$

$$V_c = 0$$

$$I_a = I_{a0} + I_{a1} + I_{a2} = 0$$

$$I_f = I_b + I_c$$

$$\begin{bmatrix} V_{a0} \\ V_{a1} \\ V_{a2} \end{bmatrix} = \frac{1}{3} \begin{bmatrix} 1 & 1 & 1 \\ 1 & a & a^2 \\ 1 & a^2 & a \end{bmatrix} \begin{bmatrix} V_a \\ 0 \\ 0 \end{bmatrix}$$

$$V_{a0} = V_{a1} = V_{a2}$$

Double Line to Ground Fault

$$I_{a1} = \left(1 + \frac{Z_1}{Z_0} + \frac{Z_1}{Z_2} \right) = V_{a1} \frac{Z_2 + Z_0}{Z_2 Z_0}$$

$$I_{a1} = \frac{V_{a1} (Z_0 + Z_2)}{(Z_1 Z_0 + Z_2 Z_0 + Z_1 Z_2)}$$

$$I_{a0} = \frac{V_{a1}}{\left(Z_1 + \frac{Z_0 Z_2}{Z_0 + Z_2} \right)}$$

$$I_{a0} = -\frac{V_{a0}}{Z_0}, \quad I_{a2} = -\frac{V_{a2}}{Z_2}$$

Network Diagram

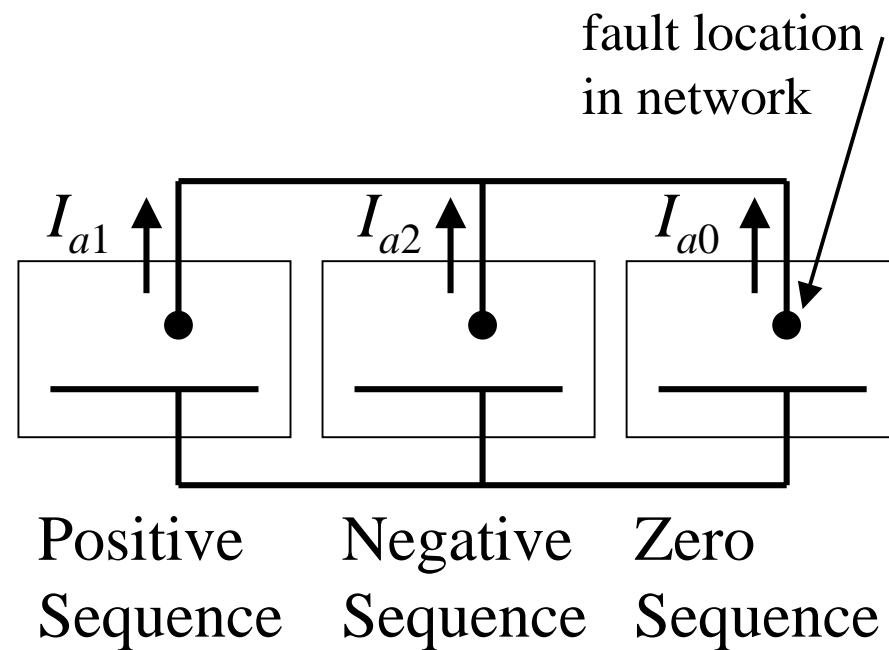

Double Line to Ground Fault

$$I_{a0} + I_{a1} + I_{a2} = 0$$

$$\mathbf{I}_{abc} = \mathbf{A} \mathbf{I}_{012}$$

$$I_f = I_b + I_c$$

$$= I_{a0} + a^2 I_{a1} + a I_{a2} + I_{a0} + a I_{a1} + a^2 I_{a2}$$

$$= 2 I_{a0} + a^2 (I_{a1} + I_{a2}) + a (I_{a1} + I_{a2})$$

$$= 2 I_{a0} + (a^2 + a)(I_{a1} + I_{a2})$$

$$(a^2 + a) = -1$$

$$I_f = 2 I_{a0} - (I_{a1} + I_{a2})$$

Line-to-Line Fault

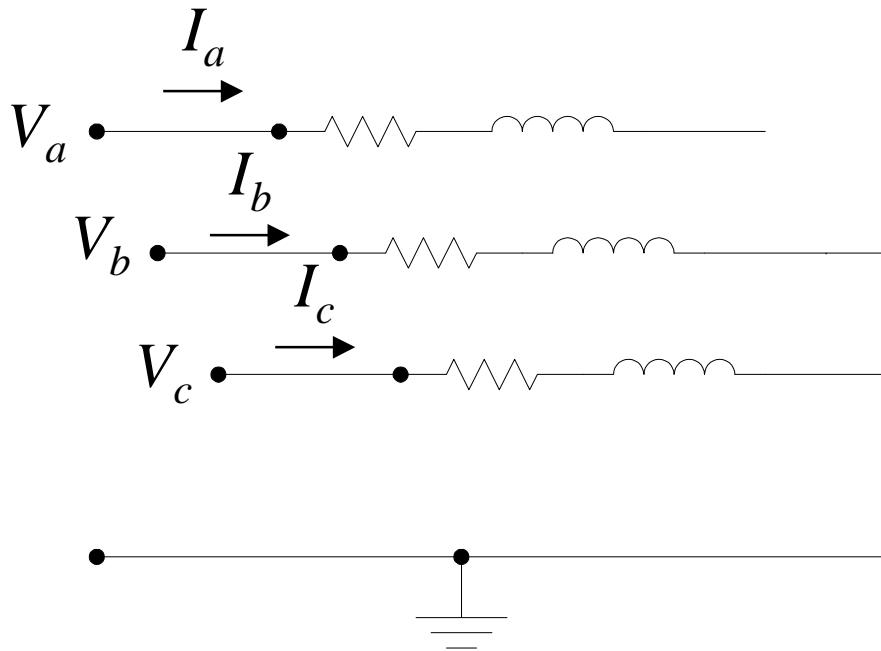

$$V_b - V_c = 0$$

$$I_b + I_c = 0$$

$$I_a = I_{a0} + I_{a1} + I_{a2} = 0$$

$$I_f = I_b - I_c$$

$$\begin{bmatrix} I_{a0} \\ I_{a1} \\ I_{a2} \end{bmatrix} = \frac{1}{3} \begin{bmatrix} 1 & 1 & 1 \\ 1 & a & a^2 \\ 1 & a^2 & a \end{bmatrix} \begin{bmatrix} 0 \\ I_b \\ -I_b \end{bmatrix}$$

Line-to-Line Fault

$$\begin{bmatrix} I_{a0} \\ I_{a1} \\ I_{a2} \end{bmatrix} = \frac{1}{3} \begin{bmatrix} 1 & 1 & 1 \\ 1 & a & a^2 \\ 1 & a^2 & a \end{bmatrix} \begin{bmatrix} 0 \\ I_b \\ -I_b \end{bmatrix}$$

$$I_{a0} = 0$$

$$I_{a1} = \frac{1}{3}(a - a^2)I_b$$

$$I_{a2} = \frac{1}{3}(a^2 - a)I_b$$

$$I_{a1} = -I_{a2}$$

Network Diagram

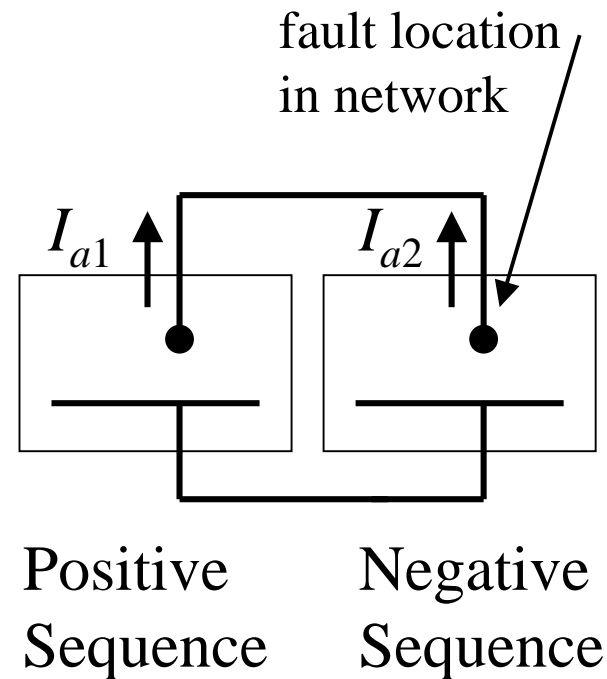

Line-to-Line Fault

$$V_b - V_c = (a^2 - a)(V_k^{a1} - V_k^{a2}) = 0$$

$$V_k^{a1} = V_a - Z_k^1 I_{a1}$$

$$V_k^{a2} = -Z_k^2 I_k^{a2} = Z_k^2 I_k^{a1}$$

$$(a^2 - a) \left[V_a - (Z_k^1 + Z_k^2) I_k^{a1} \right] = 0$$

$$V_k^a - (Z_k^1 + Z_k^2) I_k^{a1} = 0$$

$$I_k^{a1} = \frac{V_{k,pre-f}^a}{Z_k^1 + Z_k^2}$$

Line-to-Line Fault

$$I_k^{a1} = -I_k^{a2}$$

$$\begin{bmatrix} I_a \\ I_b \\ I_c \end{bmatrix} = \begin{bmatrix} 1 & 1 & 1 \\ 1 & a^2 & a \\ 1 & a & a^2 \end{bmatrix} \begin{bmatrix} 0 \\ I_k^{a1} \\ -I_k^{a1} \end{bmatrix}$$

$$I_b = (a^2 - a) I_k^{a1} = -j\sqrt{3} I_k^{a1}$$

$$I_b = \frac{-j\sqrt{3} V_k^a}{Z_k^1 + Z_k^2}$$

$$I_c = -I_b$$

Example

- ◆ The neutral of each generator is grounded through a current limiting resistor of 8.333 % on a 100 MVA base
- ◆ generators are running at no-load at rated voltage and in phase
- ◆ all network data is expressed on a 100 MVA base
- ◆ Find the fault current for 3-phs, 1-phs, L-L, L-L-G bolted faults

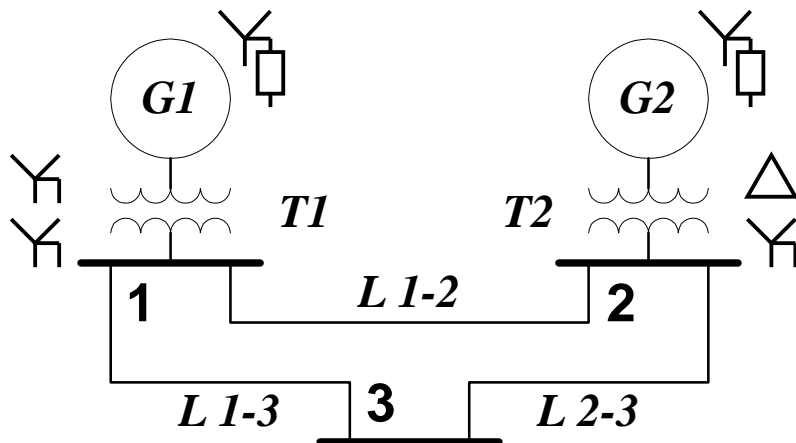

<u>Item</u>	<u>V Rating</u>	<u>X1</u>	<u>X2</u>	<u>X0</u>
G1	20 kV	15%	15%	5%
G2	20 kV	15%	15%	5%
T1	20/200 kV	10%	10%	10%
T2	20/200 kV	10%	10%	10%
L 1-2	200 kV	12.5%	12.5%	30%
L 1-3	200 kV	15%	15%	35%
L 2-3	200 kV	25%	25%	71.25%

Example

- Positive Sequence Network

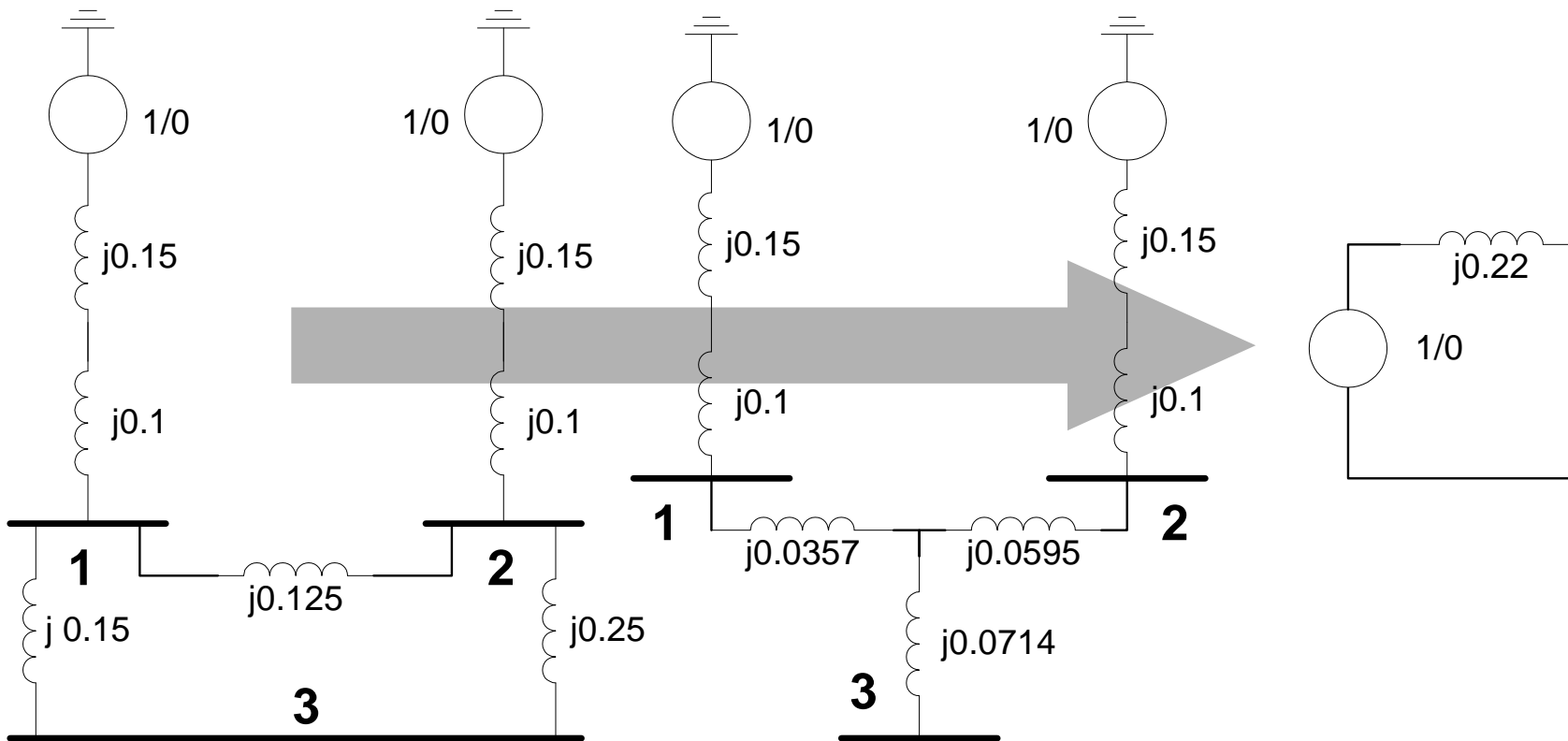

Example

- Negative Sequence Network

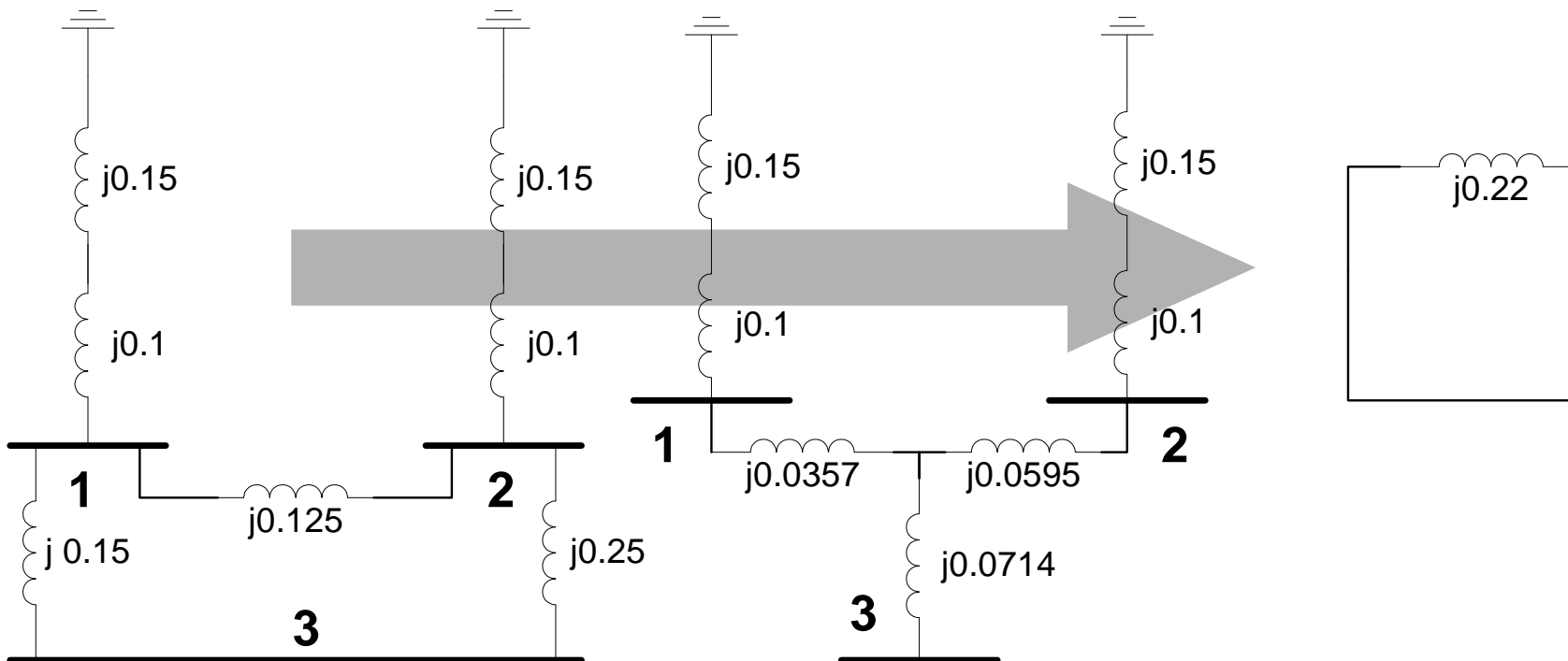

Example

- Zero Sequence Network

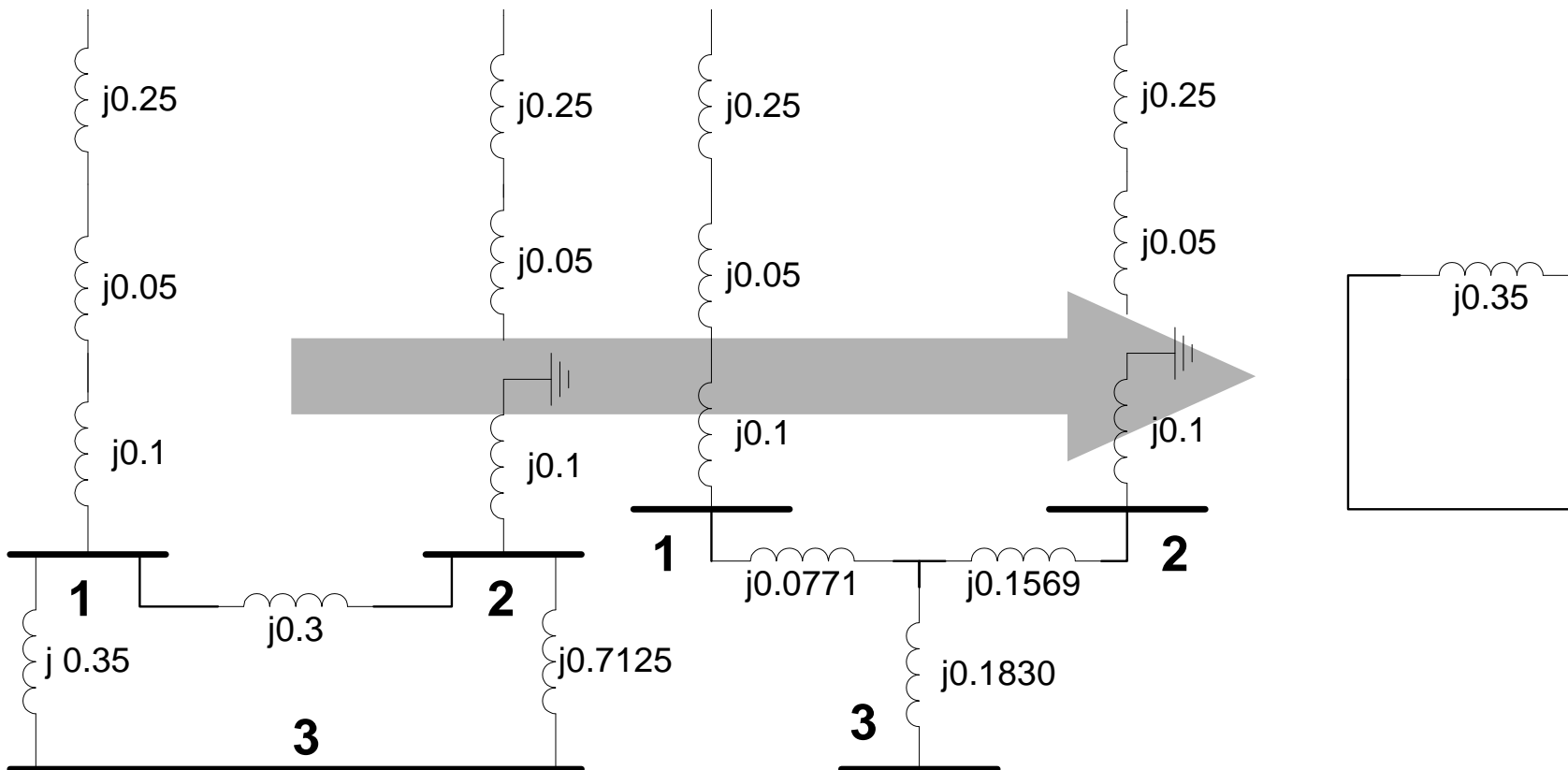

Example

- **3-phase fault**

$$I_3^{a1}(F) = \frac{V_3^{a1}}{Z_{33}^1} = \frac{1.0 \angle 0^\circ}{j0.22} = -j4.54 \text{ pu}$$

$$I_{af} = I_3^{a1}(F) = -j4.54 \text{ pu}$$

- **SLG fault**

$$\begin{aligned} I_3^{a0} = I_3^{a1} = I_3^{a2} &= \frac{V_3^{a1}}{Z_{33}^0 + Z_{33}^1 + Z_{33}^2} \\ &= \frac{1.0 \angle 0^\circ}{j0.35 + j0.22 + j0.22} = -j1.266 \text{ pu} \end{aligned}$$

$$I_{af} = 3I_3^{a1} = -j3.80 \text{ pu}$$

Example

- L-L fault

$$I_3^{a0} = 0$$

$$I_3^{a1} = -I_3^{a2} = \frac{V_3^{a1}}{Z_{33}^1 + Z_{33}^2} = \frac{1.0 \angle 0^\circ}{j0.22 + j0.22} = -j2.27 \text{ pu}$$

$$I_{bf} = -I_{cf} = -j\sqrt{3}(-j2.27) = -3.936 \text{ pu}$$

Example

- **DLG fault**

$$I_3^{a1} = \frac{V_3^{a1}}{Z_{33}^1 + \frac{Z_{33}^0 \cdot Z_{33}^2}{Z_{33}^0 + Z_{33}^2}} = \frac{1.0 \angle 0^\circ}{j0.22 + \frac{j0.35 \cdot j0.22}{j0.35 + j0.22}} = -j2.816 \text{ pu}$$

$$I_3^{a2} = -\frac{V_3^{a1} - Z_{33}^1 I_3^{a1}}{Z_{33}^2} = -\frac{1.0 \angle 0^\circ - (j0.22) \cdot (-j2.816)}{j0.22} = j1.729 \text{ pu}$$

$$I_3^{a0} = -\frac{V_3^{a1} - Z_{33}^1 I_3^{a1}}{Z_{33}^0} = -\frac{1.0 \angle 0^\circ - (j0.22) \cdot (-j2.816)}{j0.35} = j1.087 \text{ pu}$$

$$\begin{aligned} I_f &= I_3^b + I_3^c = 2I_3^{a0} + (a + a^2)(I_3^{a1} + I_3^{a2}) \\ &= 2(j1.087) - (-j2.816 + j1.729) = j3.261 \text{ pu} \end{aligned}$$

Fault Analysis with Fault Impedances

- **Single Line to Ground Fault**

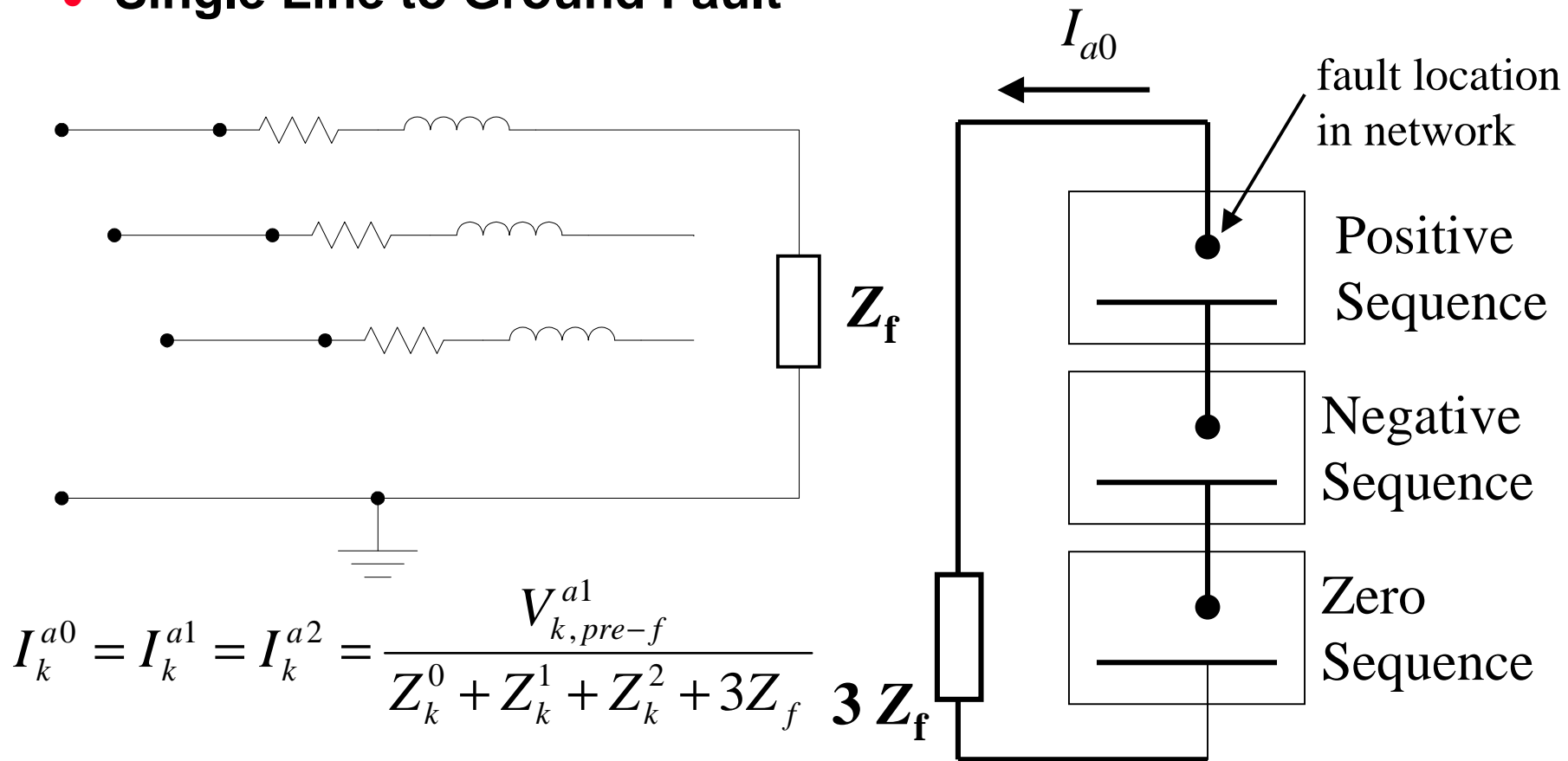

Fault Analysis with Fault Impedances

- Double Line to Ground Fault

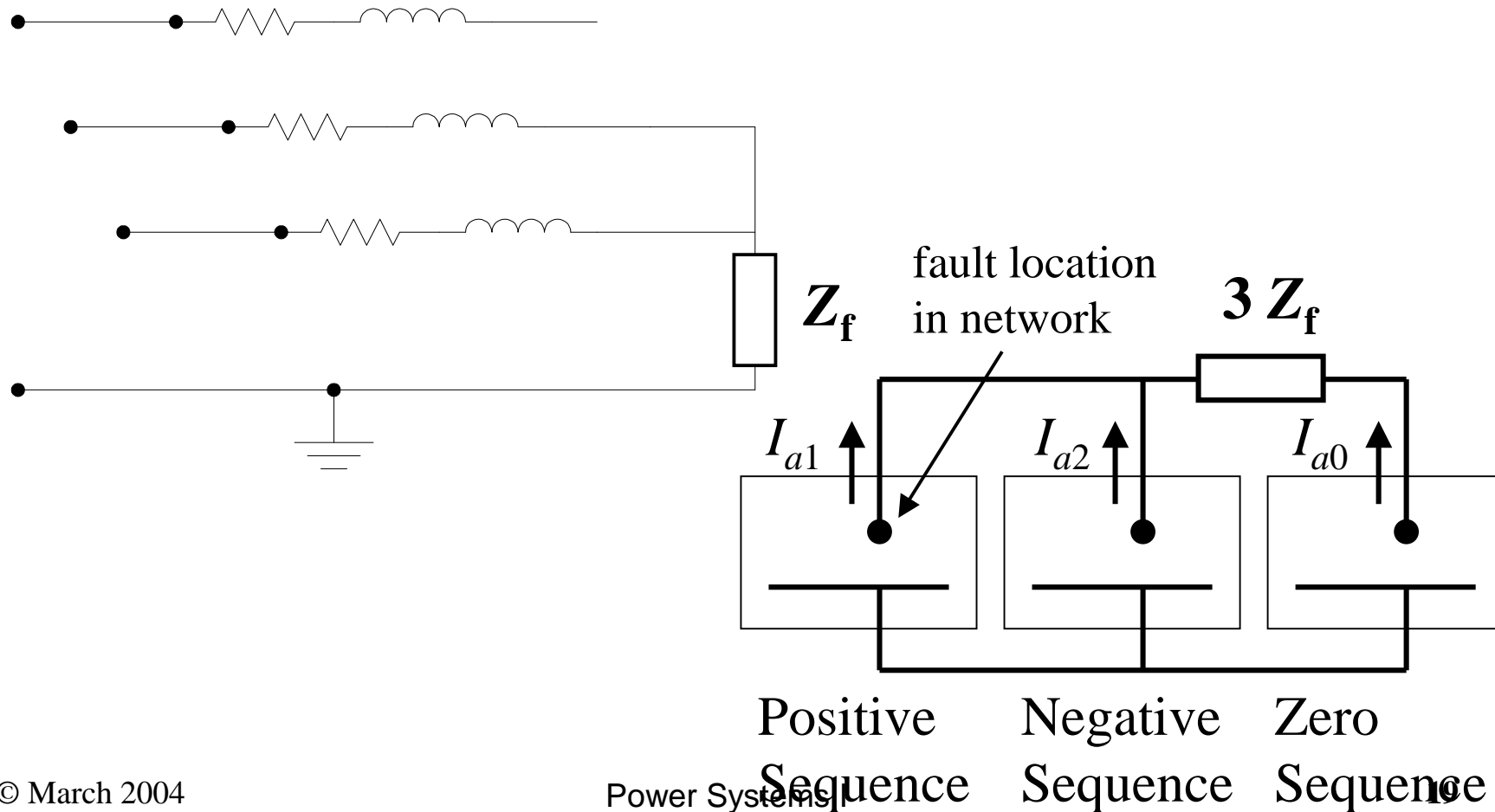

Fault Analysis with Fault Impedances

- Double Line to Ground Fault

$$I_k^{a1} = \frac{V_k^{a1}}{Z_k^1 + (Z_k^0 + 3Z_f) \cdot Z_k^2 / (Z_k^0 + 3Z_f + Z_k^2)}$$

$$I_k^{a2} = -\frac{V_k^{a1} - Z_k^1 I_k^{a1}}{Z_k^2}$$

$$I_k^{a0} = -\frac{V_k^{a1} - Z_k^1 I_k^{a1}}{Z_k^0 + 3Z_f}$$

Fault Analysis with Fault Impedances

- Line to Line Fault

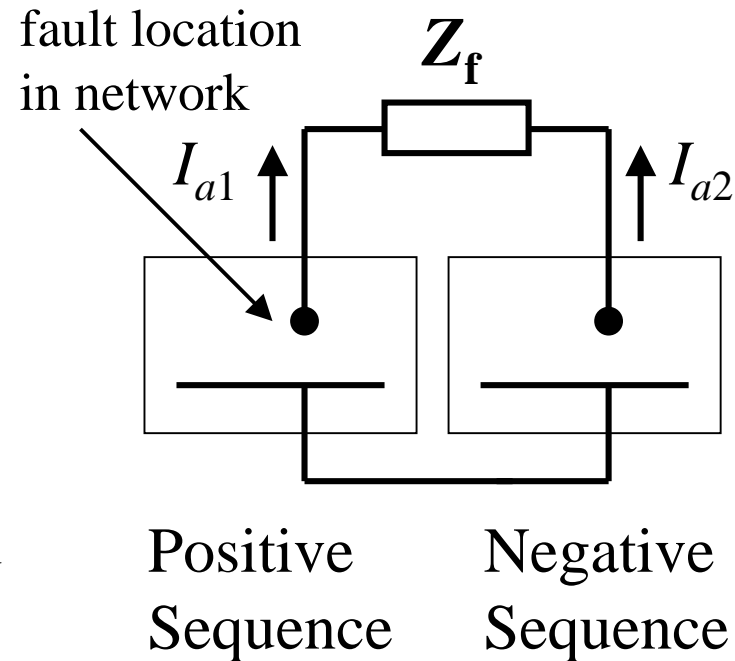
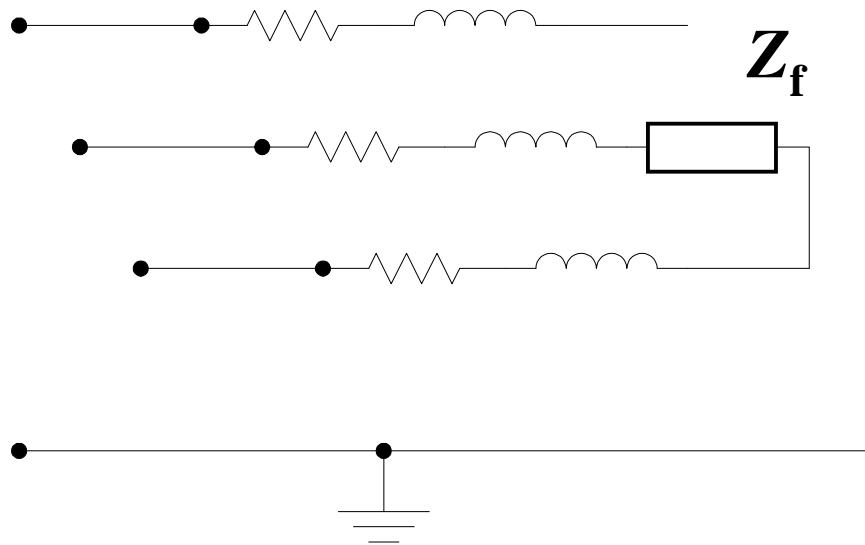

$$I_k^{a1} = -I_k^{a2} = \frac{V_k^a}{Z_k^1 + Z_k^2 + Z_f}$$

Fault Analysis using Z-Bus Matrix

- **Form the Positive Sequence and the Zero Sequence bus impedance matrices**
 - ◆ The Negative Sequence matrix is the same as the Positive Sequence matrix
- **Use the diagonal element of the faulted bus with the following modified fault equations**

Fault Analysis using Z-Bus Matrix

- **Single Line to Ground Fault**

$$I_k^{a0} = I_k^{a1} = I_k^{a2} = \frac{V_{k,pre-f}^{a1}}{\mathbf{Z}_{kk}^0 + 2 \cdot \mathbf{Z}_{kk}^1 + \mathbf{Z}_f}$$

- **Line to Line Fault**

$$I_k^{a1} = -I_k^{a2} = \frac{V_k^a}{2 \cdot \mathbf{Z}_{kk}^1 + \mathbf{Z}_f}$$

Fault Analysis using Z-Bus Matrix

- Double Line to Ground Fault

$$I_k^{a1} = \frac{V_k^{a1}}{\mathbf{Z}_{kk}^1 + (\mathbf{Z}_{kk}^0 + 3Z_f) \cdot \mathbf{Z}_{kk}^1 / (\mathbf{Z}_{kk}^0 + 3Z_f + \mathbf{Z}_{kk}^1)}$$

$$I_k^{a2} = -\frac{V_k^{a1} - \mathbf{Z}_{kk}^1 I_k^{a1}}{\mathbf{Z}_{kk}^1}$$

$$I_k^{a0} = -\frac{V_k^{a1} - \mathbf{Z}_{kk}^1 I_k^{a1}}{\mathbf{Z}_{kk}^0 + 3Z_f}$$

Fault Analysis using Z-Bus Matrix

- **Bus voltages during fault**

$$V_i^{a0} = 0 - Z_{ik}^0 I_k^{a0}$$

$$V_i^{a1} = V_i^a - Z_{ik}^1 I_i^{a1}$$

$$V_i^{a2} = 0 - Z_{ik}^2 I_k^{a2}$$

- **Line currents during fault**

$$I_{ij}^{a0} = (V_i^{a0} - V_j^{a0}) / Z_{ij}^0$$

$$I_{ij}^{a1} = (V_i^{a1} - V_j^{a1}) / Z_{ij}^1$$

$$I_{ij}^{a2} = (V_i^{a2} - V_j^{a2}) / Z_{ij}^2$$