

**OPERATIONAL PURCHASE ORDER CONFIRMATION N° 63AHF17BECA0695**

Printing Date : 30/03/2017

**[ ORIGINAL ]**

Page 1 / 14

This order is part of Global Order N° : 63AHF170030

**Issued by**

CARREFOUR GLOBAL SOURCING ASIA LTD  
18/F,ONE KOWLOON,  
NO.1,WANG YUE STREET  
KOWLOON BAY,KOWLOON,HONG KONG  
CHINA

**Beneficiary client**

( *CARREFOUR BELGIUM SA* )  
AVENUE DES OLYMPIADES,20B  
OLYMPIADENLAAN - EVERE 3  
BP 500 1140 BRUXELLES  
BELGIUM

**Supplier**

TUSUKA TROUSERS LTD.  
KONABARI, NEEL NAGAR  
GAZIPUR  
BANGLADESH

**Delivery address**

ENT BELGIQUE

**Payment Address**

CARREFOUR IMPORT SAS  
( *CARREFOUR IMPORT SAS* )  
93 AVENUE DE PARIS  
91300 MASSY  
FRANCE

Incoterm : FOB DHAKA SEA

POL : DHAKA SEA - BANGLADESH

POD : ANTWERPEN(ANVERS) - BELGIUM

Currency : US DOLLAR

Payment : LC AT 120 DAYS FROM SHIPMENT DATE

Total amount : 58,553.28

**ORDER INDEX**

Chapter	Page	Description
<b>I. PRODUCT DESCRIPTION</b>		Product description, color, size, gencode details and specific documents required
<b>II. GENERAL DOCUMENTS</b>		Documents required for all the order items
<b>III. OPERATIONAL SHIPMENT DETAILS</b>		List of order items sorted by ETD
<b>IV. WAREHOUSES ADDRESSES</b>		
<b>V. COMMENTS</b>		<b>Specific instructions - please read carefully</b>
<b>VI. GENERAL PURCHASING CONDITIONS</b>		

**OPERATIONAL PURCHASE ORDER CONFIRMATION N° 63AHF17BECA0695**

Printing Date : 30/03/2017

**[ ORIGINAL ]**

This order is part of Global Order N° : 63AHF170030

**I. PRODUCT DESCRIPTION**

**PRODUCT / PACKING # 1**

**Packing : SOLID COLOR-1 COLOR/N SIZES    Product origin : BANGLADESH  
Commission rate : 6.00**

**JEAN SLIM ESSENTIEL DENIM**

Product description : JEAN SLIM ESSENTIEL DENIM  
JEANSY DAMSKIE TKANE  
JEAN SLIM ESSENTIEL DENIM,

Product composition : SHELL:69%,COTTON | SHELL:1%,ELASTANE | SHELL:23%,POLYESTER | SHELL:7%,RAYON

Carrefour reference	Supplier's reference	Client reference	Color	Size	Customs class	Category number	Pack. type	Assortment		Master ctn barcode	Inner ctn barcode	Unit barcode	Pallet dimension (cm)	Master carton (cm)	Gross wt (kg)	Quantity ordered			Unit price	Total price	
								master	break.							Pallet	Master	Unit			
1793017	1793017		JEF		6203423100	6	Ass. color	10		03615001044877				L : 59.0 W : 39.0 H : 13.0	6.5		118	1,180	8.574	10,117.32	
			JEF	36	6203423100	6			1			3614614263606							118		
			JEF	38	6203423100	6			2			3614614263613							236		
			JEF	40	6203423100	6			2			3614614263620							236		
			JEF	42	6203423100	6			2			3614614263637							236		
			JEF	44	6203423100	6			1			3614614263644							118		
			JEF	46	6203423100	6			1			3614614263651							118		
			JEF	48	6203423100	6			1			3614614263668							118		
1793017	1793017		MAF		6203423100	6	Ass. color	10		03615001044907				L : 59.0 W : 39.0 H : 13.0	6.5		118	1,180	8.574	10,117.32	
			MAF	36	6203423100	6			1			3614614263811							118		
			MAF	38	6203423100	6			2			3614614263828							236		
			MAF	40	6203423100	6			2			3614614263835							236		
			MAF	42	6203423100	6			2			3614614263842							236		
			MAF	44	6203423100	6			1			3614614263859							118		
			MAF	46	6203423100	6			1			3614614263866							118		
			MAF	48	6203423100	6			1			3614614263873							118		
																			<b>TOTAL</b>		<b>20,234.64</b>
																			<b>236</b>	<b>2,360</b>	

**Color details :**    JEF = STONE DARK, MAF = NAVY DARK

**National merchandise structure :**    61623420003

**SPECIFIC DOCUMENTS :**

**OPERATIONAL PURCHASE ORDER CONFIRMATION N° 63AHF17BECA0695**

Printing Date : 30/03/2017

**[ ORIGINAL ]**

Page 3 / 14

This order is part of Global Order N° : 63AHF170030

Document	Description	Customs class	Category number	Nb original	Nb copy
865	CERTIFICATE OF ORIGIN GSP FORM A	6203423100		1	1

**SPECIFIC CUSTOMS INSTRUCTIONS :**

CERTIFICATE OF ORIGIN FOR TEXTILE PRODUCTS UNNECESSARY IF AN APPLICABLE AND VALID GSP FORM A IS PROVIDED

**OPERATIONAL PURCHASE ORDER CONFIRMATION N° 63AHF17BECA0695**

Printing Date : 30/03/2017

**[ ORIGINAL ]**

This order is part of Global Order N° : 63AHF170030

**PRODUCT / PACKING # 2**

**Packing : SOLID COLOR-1 COLOR/N SIZES    Product origin : BANGLADESH  
Commission rate : 6.00**

**JEAN DROIT ESSENTIEL DENIM**

Product description : JEAN DROIT ESSENTIEL DENIM  
JEANSY DAMSKIE TKANE  
JEAN DROIT ESSENTIEL DENIM,

Product composition : SHELL:69%,COTTON | SHELL:1%,ELASTANE | SHELL:23%,POLYESTER | SHELL:7%,RAYON

Carrefour reference	Supplier's reference	Client reference	Color	Size	Customs class	Category number	Pack. type	Assortment		Master ctn barcode	Inner ctn barcode	Unit barcode	Pallet dimension (cm)	Master carton (cm)	Gross wt (kg)	Quantity ordered			Unit price	Total price				
								master	break.							Pallet	Master	Unit						
1793030	1793030		MAC		6203423100	6	Ass. color	10		03615001044938				L : 59.0 W : 39.0 H : 13.0	6.5		168	1,680	8,674	14,572.32				
			MAC	36	6203423100	6			1			3614614264030							168					
			MAC	38	6203423100	6			2			3614614264047							336					
			MAC	40	6203423100	6			2			3614614264054							336					
			MAC	42	6203423100	6			2			3614614264061							336					
			MAC	44	6203423100	6			1			3614614264078							168					
			MAC	46	6203423100	6			1			3614614264085							168					
			MAC	48	6203423100	6			1			3614614264092							168					
1793030	1793030		MAF		6203423100	6	Ass. color	10		03615001044945				L : 59.0 W : 39.0 H : 13.0	6.5		168	1,680	8,674	14,572.32				
			MAF	36	6203423100	6			1			3614614264108							168					
			MAF	38	6203423100	6			2			3614614264115							336					
			MAF	40	6203423100	6			2			3614614264122							336					
			MAF	42	6203423100	6			2			3614614264139							336					
			MAF	44	6203423100	6			1			3614614264146							168					
			MAF	46	6203423100	6			1			3614614264153							168					
			MAF	48	6203423100	6			1			3614614264160							168					
																			<b>TOTAL</b>		<b>336</b>	<b>3,360</b>		<b>29,144.64</b>

**Color details :**    MAC = NAVY LIGHT, MAF = NAVY DARK

**National merchandise structure :**    61623420003

**SPECIFIC DOCUMENTS :**

**OPERATIONAL PURCHASE ORDER CONFIRMATION N° 63AHF17BECA0695**

Printing Date : 30/03/2017

**[ ORIGINAL ]**

Page 5 / 14

This order is part of Global Order N° : 63AHF170030

Document	Description	Customs class	Category number	Nb original	Nb copy
865	CERTIFICATE OF ORIGIN GSP FORM A	6203423100		1	1

**SPECIFIC CUSTOMS INSTRUCTIONS :**

CERTIFICATE OF ORIGIN FOR TEXTILE PRODUCTS UNNECESSARY IF AN APPLICABLE AND VALID GSP FORM A IS PROVIDED

**OPERATIONAL PURCHASE ORDER CONFIRMATION N° 63AHF17BECA0695**

Printing Date : 30/03/2017

**[ ORIGINAL ]**

This order is part of Global Order N° : 63AHF170030

**PRODUCT / PACKING # 3**

Packing : SOLID COLOR-1 COLOR/N SIZES Product origin : BANGLADESH  
Commission rate : 6.00

**JEAN DROIT ESSENTIEL NOIR**

Product description : JEAN DROIT ESSENTIEL NOIR,

Product composition : SHELL:99%,COTTON | SHELL:1%,ELASTANE

Carrefour reference	Supplier's reference	Client reference	Color	Size	Customs class	Category number	Pack. type	Assortment		Master ctn barcode	Inner ctn barcode	Unit barcode	Pallet dimension (cm)	Master carton (cm)	Gross wt (kg)	Quantity ordered			Unit price	Total price
								master	break							Pallet	Master	Unit		
I793031	I793031		NR1		6203423100	6	Ass. color	10		03615001044969				L : 59.0 W : 39.0 H : 13.0	6.5		100	1,000	9,174	9,174.00
			NR1	36	6203423100	6			1			3614614264252							100	
			NR1	38	6203423100	6			2			3614614264269							200	
			NR1	40	6203423100	6			2			3614614264276							200	
			NR1	42	6203423100	6			2			3614614264283							200	
			NR1	44	6203423100	6			1			3614614264290							100	
			NR1	46	6203423100	6			1			3614614264306							100	
			NR1	48	6203423100	6			1			3614614264313							100	
														<b>TOTAL</b>			<b>100</b>	<b>1,000</b>		<b>9,174.00</b>

Color details : NR1 = BLACK 1

National merchandise structure : 61623420003

**SPECIFIC DOCUMENTS :**

Document	Description	Customs class	Category number	Nb original	Nb copy
865	CERTIFICATE OF ORIGIN GSP FORM A	6203423100		1	1

**SPECIFIC CUSTOMS INSTRUCTIONS :**

CERTIFICATE OF ORIGIN FOR TEXTILE PRODUCTS UNNECESSARY IF AN APPLICABLE AND VALID GSP FORM A IS PROVIDED

**OPERATIONAL PURCHASE ORDER CONFIRMATION N° 63AHF17BECA0695**

Printing Date : 30/03/2017

**[ ORIGINAL ]**

Page 7 / 14

This order is part of Global Order N° : 63AHF170030

**II. GENERAL DOCUMENTS REQUIRED**

Document	Description	Customs class	Category number	Nb Original	Nb Copy
271	PACKING LIST			1	2
380	COMMERCIAL INVOICE			2	3
624	FORWARDER'S CERTIFICATE OF RECEIPT			1	1

**OPERATIONAL PURCHASE ORDER CONFIRMATION N° 63AHF17BECA0695**

Printing Date : 30/03/2017

**[ ORIGINAL ]**

This order is part of Global Order N° : 63AHF170030

**Freight forwarder at origin :**  
 MGH LOGISTICS ASIA PTE LTD  
 GATEWAY EAST 14 04  
 152 BEACH ROAD  
 SINGAPORE  
 SINGAPORE

**Transport :** SEA  
 Incoterm : FOB DHAKA SEA  
 POL : DHAKA SEA - BANGLADESH  
 POD : ANTWERPEN(ANVERS) - BELGIUM  
 Payment : LC AT 120 DAYS FROM SHIPMENT DATE  
 Currency : US DOLLAR

**III. OPERATIONAL SHIPMENT DETAILS**

FRI date	Packing list transm. date	Cargo receiving date	Required ETD	POL	POD	Warehouse	Master barcode	Pack. type	Import reference	Product description Color - Size	Quantities			Gross volume (m3)	Net Volume (m3)	Gross Weight (kg)	Net Weight (kg)	Promo units
											Palett	Master	Units					
17/04/2017	22/04/2017	24/04/2017	28/04/2017	BDICD DHAKA SEA - BANGLADESH	BEANR ANTWERPE - BELGIUM	ENT BELGIQUE BELGIUM	03615001044877	Assorted by color	1793017	JEAN SLIM ESSENTIEL DENIM  JEF		118	1,180	3.54	3.54	767.0	590.0	
17/04/2017	22/04/2017	24/04/2017				ENT BELGIQUE BELGIUM	03615001044907	Assorted by color	1793017	JEAN SLIM ESSENTIEL DENIM  MAF		118	1,180	3.54	3.54	767.0	590.0	
17/04/2017	22/04/2017	24/04/2017				ENT BELGIQUE BELGIUM	03615001044938	Assorted by color	1793030	JEAN DROIT ESSENTIEL DENIM  MAC		168	1,680	5.04	5.04	1,092.0	840.0	
17/04/2017	22/04/2017	24/04/2017				ENT BELGIQUE BELGIUM	03615001044945	Assorted by color	1793030	JEAN DROIT ESSENTIEL DENIM  MAF		168	1,680	5.04	5.04	1,092.0	840.0	
17/04/2017	22/04/2017	24/04/2017				ENT BELGIQUE BELGIUM	03615001044969	Assorted by color	1793031	JEAN DROIT ESSENTIEL NOIR  NR1		100	1,000	3.0	3.0	650.0	500.0	
<b>TOTAL :</b>												<b>672</b>	<b>6,720</b>	<b>20.16</b>	<b>20.16</b>	<b>4,368.0</b>	<b>3,360.0</b>	



**OPERATIONAL PURCHASE ORDER CONFIRMATION N° 63AHF17BECA0695**

Printing Date : 30/03/2017

**[ ORIGINAL ]**

Page 9 / 14

This order is part of Global Order N° : 63AHF170030

**IV. WAREHOUSES ADDRESSES**

Code	Address
ENT BELGIQUE	BELGIUM WAREHOUSE - VILVOORDE HAVENDOKLAAN 18 1800 VILVOORDE BELGIQUE BELGIUM

**OPERATIONAL PURCHASE ORDER CONFIRMATION N° 63AHF17BECA0695**

Printing Date : 30/03/2017

**[ ORIGINAL ]**

Page 10 / 14

This order is part of Global Order N° : 63AHF170030

**V. COMMENTS**

The marketing of ordered products will be invoiced separately. In the event of the non-payment of this invoice by the deadline, Carrefour Import reserves the right to deduct the outstanding sum upon presentation of a letter of credit to the bank or the issuing of a SWIFT payment.

in case of consolidation (cfs), goods must be delivered at consolidation platform at least 10 days before etd

**OPERATIONAL PURCHASE ORDER CONFIRMATION N° 63AHF17BECA0695**

Printing Date : 30/03/2017

**[ ORIGINAL ]**

This order is part of Global Order N° : 63AHF170030

CARREFOUR GLOBAL SOURCING  
MANAGING DIRECTOR

**DE BELLESCIZE XAVIER**



CARREFOUR IMPORT SAS  
GROUP IMPORT DIRECTOR

**SALAMA BENDAYAN SAMUEL**



**IF AN INNER EXISTS, SHIPPING MARKS MUST BE PRINTED ON BOTH CARTON BOXES**

Item I793017 :

Shipping mark SOLID COLOR-1 COLOR/N SIZES

CARREFOUR BELGIUM SA
63AHF17BECA0695
I793017
PANTALON DENIM 5 POCHE SLIM
Made in BANGLADESH

Side Mark : Packing assorted by color

DIMENSIONS : _____ CMS											
NET WEIGHT : _____ KGS											
GROSS WEIGHT : _____ KGS											
<b>COLOR : STONE DARK</b>											
Size	36	38	40	42	44	46	48				UNITS
Qty	1	2	2	2	1	1	1				10
CARTON N# : _____											

DIMENSIONS : _____ CMS											
NET WEIGHT : _____ KGS											
GROSS WEIGHT : _____ KGS											
<b>COLOR : NAVY DARK</b>											
Size	36	38	40	42	44	46	48				UNITS
Qty	1	2	2	2	1	1	1				10
CARTON N# : _____											

**OPERATIONAL PURCHASE ORDER CONFIRMATION N° 63AHF17BECA0695**

Printing Date : 30/03/2017

**[ ORIGINAL ]**

This order is part of Global Order N° : 63AHF170030

**IF AN INNER EXISTS, SHIPPING MARKS MUST BE PRINTED ON BOTH CARTON BOXES**

**Item I793030 :**

**Shipping mark SOLID COLOR-1 COLOR/N SIZES**

CARREFOUR BELGIUM SA
63AHF17BECA0695
I793030
PANTALON DENIM 5 POCHEs SLIM
Made in BANGLADESH

**Side Mark : Packing assorted by color**

DIMENSIONS : _____ CMS											
NET WEIGHT : _____ KGS											
GROSS WEIGHT : _____ KGS											
<b>COLOR : NAVY LIGHT</b>											
Size	36	38	40	42	44	46	48				UNITS
Qty	1	2	2	2	1	1	1				10
CARTON N# : _____											

DIMENSIONS : _____ CMS											
NET WEIGHT : _____ KGS											
GROSS WEIGHT : _____ KGS											
<b>COLOR : NAVY DARK</b>											
Size	36	38	40	42	44	46	48				UNITS
Qty	1	2	2	2	1	1	1				10
CARTON N# : _____											

**OPERATIONAL PURCHASE ORDER CONFIRMATION N° 63AHF17BECA0695**

Printing Date : 30/03/2017

**[ ORIGINAL ]**

This order is part of Global Order N° : 63AHF170030

**IF AN INNER EXISTS, SHIPPING MARKS MUST BE PRINTED ON BOTH CARTON BOXES**

**Item I793031 :**

**Shipping mark SOLID COLOR-1 COLOR/N SIZES**

CARREFOUR BELGIUM SA
63AHF17BECA0695
I793031
PANTALON DENIM 5 POCHE SLIM
Made in BANGLADESH

**Side Mark : Packing assorted by color**

DIMENSIONS	:	_____	CMS									
NET WEIGHT	:	_____	KGS									
GROSS WEIGHT	:	_____	KGS									
<b>COLOR : BLACK 1</b>												
Size	36	38	40	42	44	46	48					UNITS
Qty	1	2	2	2	1	1	1					10
CARTON N# : _____												

# OPERATIONAL PURCHASE ORDER CONFIRMATION N° 63AHF17BECA0695

Printing Date : 30/03/2017

## [ ORIGINAL ]

Page 14 / 14

This order is part of Global Order N° : 63AHF170030

### VI. GENERAL TERMS AND CONDITIONS FOR THE SUPPLY OF CONTROLLED PRODUCTS

**Recitals :** The various CARREFOUR Companies have entrusted Carrefour World Trade ("CWT") with negotiating the terms of purchase of Controlled Products with the suppliers of these products for their marketing by the CARREFOUR Companies in the Territory.

In respect of Asia, CWT has delegated part of its negotiation and sourcing activities to other CARREFOUR Companies including Carrefour Import and Carrefour Global Sourcing Asia.

**Acceptance of the order entails the acceptance of these terms and conditions.**

**1. Definitions - Subject** For the purposes of these terms and conditions, the terms used in capital letters have the meaning which is given to them below:  
 'Controlled Products' shall mean (i) products using the product brands or trade names of the CARREFOUR Group, (ii) products with the Supplier's brand reserved for CARREFOUR Companies, and (iii) no name products, wherever they may be sold, including those designed to be exported.  
 'Products' shall mean the Controlled Products as described in the Offer Sheets and the Product orders, which shall be manufactured by the Supplier and marketed by the CARREFOUR Companies in the Territory.  
 'Territory' shall mean: all countries where there are stores which operate under a trade name owned by the CARREFOUR Group, and all countries in which CARREFOUR shall open or acquire a store.  
 These terms and conditions are intended to determine the terms of purchase of Products which will be marketed by the CARREFOUR Companies in the Territory.  
 The Parties shall be bound by the provisions of these terms and conditions, the terms of reference, and existing or future data sheets relating to the Products, to the exclusion of any other document issued in particular by the Supplier.

**2. Definition of Products** The Products are described in the terms of reference and/or data sheets which specify their technical and qualitative characteristics, and shall form an inseparable whole with these terms and conditions.

Depending on the nature of the Products, these terms of reference and data sheets shall be subject to modifications to be determined jointly by the CARREFOUR Companies and the Supplier. Any requested modification by the CARREFOUR Companies in respect of the terms of reference or data sheets shall be transmitted by CWT or one of its designated entities to the Supplier which undertakes to comply with any reasonable modifications and sign the amended terms.

Each creation of a new Product or modification of an existing Product shall be subject to a new data sheet or new terms of reference depending on the nature of the Products, or, if need be, an amendment to the terms of reference which must be signed by the Supplier.

**3. Purchase of Products** The prices of Products, the terms and conditions of the transfer of risks, the terms of purchase of the Products are set out in the Offer Sheets and the Product orders.

**4. Compliance** 1. The Supplier undertakes to sell and deliver directly to the CARREFOUR Companies Products, including packaging, which comply strictly with the data sheets and terms of reference as well as statutory, regulatory, administrative provisions or with national or international standards in force in the countries where the Products are marketed.

Legal statements shall be written in the language of the country where the Product is marketed and shall enable identification of the Product and the Supplier.

The Supplier represents and warrants to the CARREFOUR Companies that it has obtained, to the extent required by laws or regulations, all consents, approvals, authorizations, licenses, certificates, permits and/or qualifications necessary for the performance of its obligations hereunder, including but not limited to the manufacture and export of the Products and that it enjoys the trading rights necessary to carry out export of the Products on its own.

4.2. The Supplier undertakes to make at its own expense all declarations, to apply for all approvals and authorisations provided for by the laws in the countries of destination of the Products.

4.3.4.3. In general, the Supplier undertakes to assist the CARREFOUR Companies so that the Products may be marketed under the best conditions. It shall inform the CARREFOUR Companies of any changes in the respective local laws relating to the Products.

**5. Quality control :** The Supplier undertakes to comply with the provisions of the terms of reference and data sheets relating to the compliance with and control of the quality of the Products. In addition, the Supplier undertakes to ensure complete traceability of the Products and all products and goods making up the Products, including ingredients and additives. The conditions of this traceability shall be determined in the terms of reference.

The Parties have agreed that the quality and traceability of the Products may be analysed at any time and that factory inspections may be conducted by an independent laboratory approved by the CARREFOUR Companies, in order, in particular, to ensure that the means of production are in line with the Supplier's undertakings.

The independent laboratory approved by the CARREFOUR Companies shall have access to information relating to quality and traceability, including, in particular, in the terms of reference or data sheets. Should the results of controls not be deemed satisfactory, the Supplier undertakes to implement all corrective actions determined by the Parties.

**6. Guarantees** 1. The Supplier guarantees the CARREFOUR Companies against any defects or non-compliance of the Products, packaging, declarations, labelling and, more generally, undertakes to indemnify and hold the CARREFOUR Companies harmless from and against any direct or consequential damage which the CARREFOUR Companies may suffer due to the Supplier's non-compliance with any of its obligations under these terms and conditions. In any event, the Supplier shall be responsible for all legal guarantees which are applicable in the countries where the Products are marketed in its capacity as manufacturer or supplier of Products.

In all cases, the Supplier undertakes to replace non compliant Products by Products which meet specifications or to refund them at the price paid by the CARREFOUR Companies, without prejudice to damages and/or termination of the Product orders.

6.2.6.2. Should the Supplier fail to comply with its undertakings under these general conditions, its data sheets or terms of reference, the CARREFOUR Companies may terminate any or all of their undertakings without prejudice to any damages that may be claimed from the Supplier.

6.3.6.3. The Supplier undertakes to actively assist the CARREFOUR Companies in the event of a claim or dispute relating to the conformity or quality of Products (in particular, by organising the recall of Products, press campaigns, disputes with authorities) and to assume financial responsibility for all expenses, fees, costs and damages which the CARREFOUR Companies may have to pay because of such claim or dispute.

**7. Packaging** 1. In order to optimise the design, adaptation, translation, manufacture and management of packaging, to be able to identify the Products and packaging suppliers at all times, and to take local restrictions into account, the Supplier undertakes, for each Product, to make the packaging according to the instructions which are issued to it or according to instructions specified in the terms of reference, unless the Supplier uses its packaging and its own brands for the Products. For Products marketed under brands owned by the CARREFOUR Group, the Supplier undertakes to comply with the graphic creation and chart which will be transmitted to it by the CARREFOUR Companies for printing the packaging.

7.2. In no case may this packaging be used by the Supplier, outside the scope of these terms and conditions, unless the Supplier uses its own brands for the Products.

7.3.7.3. The delivery packaging must be adapted to transport conditions so that the Products reach their destination in perfect condition. This applies particularly to deliveries to countries in Europe and Latin America and to certain Asian countries.

**8. Industrial and intellectual property** Products using own brands or trademarks of the CARREFOUR Group. The Supplier's use of industrial or intellectual property rights belonging to the CARREFOUR Group (especially trademarks, registered designs, patents relating to the Products or packaging) is strictly limited to the manufacture of the Products and the relevant packaging.

Consequently, the Supplier shall refrain from marketing or using these Products and packaging, either for its own use or for that of third parties.

The Supplier undertakes to inform CWT, expressly and in writing, within fifteen days of notification of any request from a third party which claims or which may claim to hold any rights on the trademarks and registered designs belonging to the CARREFOUR Group.

If the manufacture of one or more Products is stopped for any reason whatsoever, the Supplier shall immediately cease using the trademarks, registered designs and patents belonging to the CARREFOUR Group, and undertakes to inform the CARREFOUR Companies of the exact number of Products and packaging still in stock; the latter will either be taken back by the CARREFOUR Companies or destroyed upon their request at the Supplier's expense.

8.2. Products under the Supplier's brands reserved for CARREFOUR Companies : The CARREFOUR Companies shall have an exclusive right to use, free of charge, the trademarks and packaging which the Supplier reserves for them. Consequently, the Supplier shall refrain from using these brands and packaging, either for its own use or for that of third parties.

If the marketing of one or more Products is stopped by the CARREFOUR Companies for any reason whatsoever, the Supplier shall immediately cease using the relevant trademarks and packaging for a period of three (3) months as from the date of the last delivery.

8.3.8.3. Rules applicable to all Products : In all cases, the Supplier undertakes to deliver the Products and packaging free of all rights owned by third parties, and shall indemnify and hold the CARREFOUR Companies harmless from and against any disputes or third-party claims.

Should an action for infringement of industrial or intellectual property rights or for unfair competition be brought by any third party against the CARREFOUR Companies, the Supplier undertakes to take back the Products at the price invoiced to the CARREFOUR Companies and to refund all costs, expenses (including attorneys' costs), fees, damages and fines said Companies may have to pay. This shall be without prejudice to the right of the CARREFOUR Companies to terminate all ongoing orders for Products.

**9. Labour legislation** The Supplier undertakes that for the purposes hereof, it will only use employees who are lawfully employed, in compliance, in particular, with the rules laid down in each country of manufacture or by the international Labour Office.

**10. Respect of the environment** The Supplier undertakes, for the purposes hereof and for the manufacture of said Products, to comply with applicable regulations in respect of the environment, laid down by local and international authorities and applicable in each country where the Products are manufactured.

**11. Insurance** The Supplier guarantees that it has taken out an insurance policy covering any damage that may result from its activity and the Products with a credit worthy insurance company, and undertakes to provide the CARREFOUR Companies with a copy thereof, upon request by them.

**12. Force majeure** In the event of a case of force majeure which makes it absolutely impossible to perform one or several Product orders under the conditions stipulated by the Parties, the Supplier will inform the relevant CARREFOUR Companies as quickly as possible, and the Parties will endeavour to find a solution so that the Product orders and the terms and conditions may be performed under satisfactory conditions. Throughout the duration of the force majeure event, the CARREFOUR Companies may procure supplies from other sources.

If the case of force majeure lasts beyond a period of one (1) month, all or part of the Product orders may be terminated by the CARREFOUR Companies without prior notice.

**13. Termination** In all cases of non-performance by either Party of any of its obligations set forth in these terms and conditions and the Product orders, the other Party shall be entitled to terminate the Product orders for all or part of the Products in question, subject to a formal notice by registered mail with acknowledgement of receipt, which has been ignored for more than ten (10) days, without prejudice to damages which may be claimed from the defaulting Party.

**14. Applicable law** These terms and conditions shall be subject to Swiss law, notwithstanding any clause to the contrary which may be included in any document of any kind whatsoever which is exchanged between the Parties.

**15. Settlement of disputes - Jurisdiction** Any dispute under these terms and conditions, the Product orders, terms of reference and/or data sheet relating, in particular, to their validity, interpretation, performance or expiry (hereinafter called a 'Dispute'), shall be settled in accordance with the provisions of Clauses 15.2 to 15.4 below, notwithstanding any clause to the contrary which may be included in any other document of any kind whatsoever which is exchanged between the Parties.

19.2 15.2. Prior notification: When a Dispute arises, the first Party to take action shall send to the other Party a notification (hereinafter called the 'Notification') by fax and by registered letter with acknowledgement of receipt, or by any other method for sending mail which enables its date of receipt to be certified. This Notification shall specify: the nature and subject of the Dispute; the companies and/or persons involved in the Dispute; the territorial areas affected by the Dispute; insofar as possible, the amounts at stake.

15.3. Conciliation : Before any contentious proceedings, the Parties shall endeavour, in good faith, to settle the Dispute on an amicable basis within a period of thirty (30) days as from receipt of the Notification by registered letter or any other method for sending mail which enables its date of receipt to be certified.

The Parties intend to give to this amicable conciliation obligation full contractual authority, and expressly recognise that arbitration and/or judicial proceedings initiated by one of them in violation of the procedure described above or prior to expiry of the thirty (30) day period mentioned above shall be inadmissible.

19.4 15.4. Jurisdiction in the event of failure of conciliation : In case no settlement can be reached through amicable negotiations between the Parties within thirty (30) days as from the receipt of the Notification in accordance with the conciliation procedure described in Clause 16.3 above, the Dispute shall be exclusively and finally resolved pursuant to the Rules of Arbitration of the International Chamber of Commerce, by one or more arbitrators appointed in accordance with said Rules. Arbitration proceedings shall take place in Geneva (Switzerland), in the English language.

19.5 If the Dispute arises exclusively from problems occurring in a single country, it may nonetheless be submitted to the courts of this country, provided that one of the CARREFOUR Companies affected by this Dispute has its corporate registered address therein, and as long as the Dispute relates exclusively to:

- compliance of the Products, their packaging and labelling with regulations applicable in said country,
  - the conditions or delivery dates of the Products in said country,
  - the quality of products, their packaging or labelling and/or their compliance with the terms of reference;
- It is expressly stated that this Clause 16.4 is concluded solely for the benefit of the CARREFOUR Companies, which will, in any case, have the possibility to submit the Disputes to another jurisdiction of their choice.

ESSENTIEL SLIM 5 POCHE

Product Folders Seasonal	Women	Stage of Development	V2 Approved Without Size Set
Season	Summer 2018		
Brand	TEX	Buyer	LE GUILLOU Julia
		Technical Supervisor	LEMOINE Sandrine
Designer		Pattern Maker	LEMOINE Sandrine
			Quality Manager MAI Juliette



**Supplier:**

G.S. Bangladesh

	<b>WOMAN</b> SEASON : <b>SS18</b>	Type of product	REF: I766199	FABRIC	Fabric weight	Composition
		ESSENTIEL		DENIM	10.25 OZ	69%CO-23%PES 7%VISC-1%EA

**Factory:**

TUSUKA FASHIONS

**Factory Address:**

House D/11 Road 17  
Banani

DHAKA 1213

Bangladesh

**Factory Contact:**



GRIS FONCE

GRIS MOYEN

ESSENTIEL SLIM 5 POCHE

Product Folders Seasonal

Women

Stage of Development

V2 Approved Without Size Set

Season

Summer 2018

Brand

TEX

Buyer

LE GUILLOU Julia

Technical Supervisor

LEMOINE Sandrine

Designer

Pattern Maker

LEMOINE Sandrine

Quality Manager MAI Juliette



groupe carrefour

 groupe carrefour	<b>WOMAN</b> SEASON : <b>SS18</b>	Type of product	REF: I766199	FABRIC	Fabric weight	Composition
		ESSENTIEL				AS SWATCH

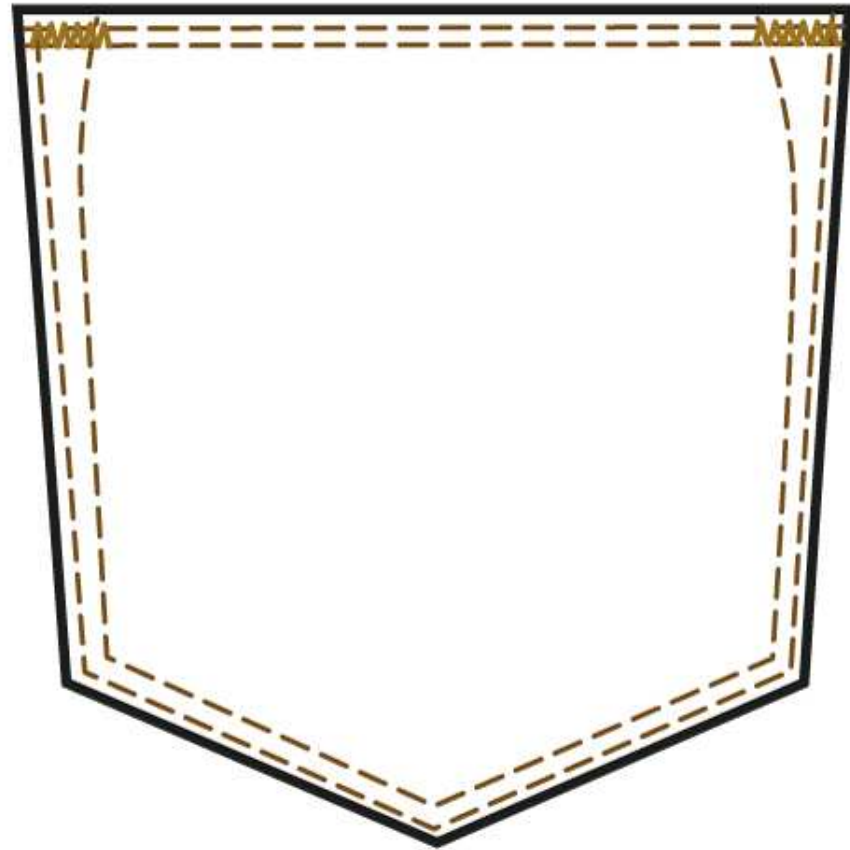
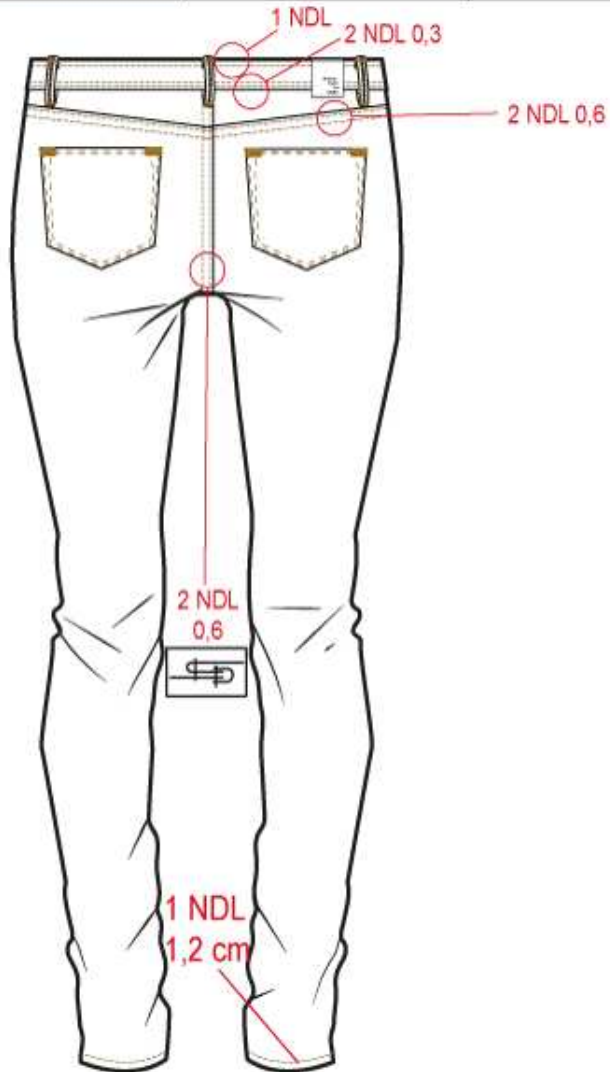



ESSENTIEL SLIM 5 POCHE

Product Folders Seasonal

Women

Stage of Development

V2 Approved Without Size Set

Season

Summer 2018

Brand

TEX

Buyer

LE GUILLOU Julia

Technical Supervisor

LEMOINE Sandrine

Designer

Pattern Maker

LEMOINE Sandrine

Quality Manager MAI Juliette



groupe carrefour

	<p><b>WOMAN</b> SEASON : <b>SS18</b></p>	Type of product	REF: 1766199	FABRIC	Fabric weight	Composition
		ESSENTIEL				AS SWATCH

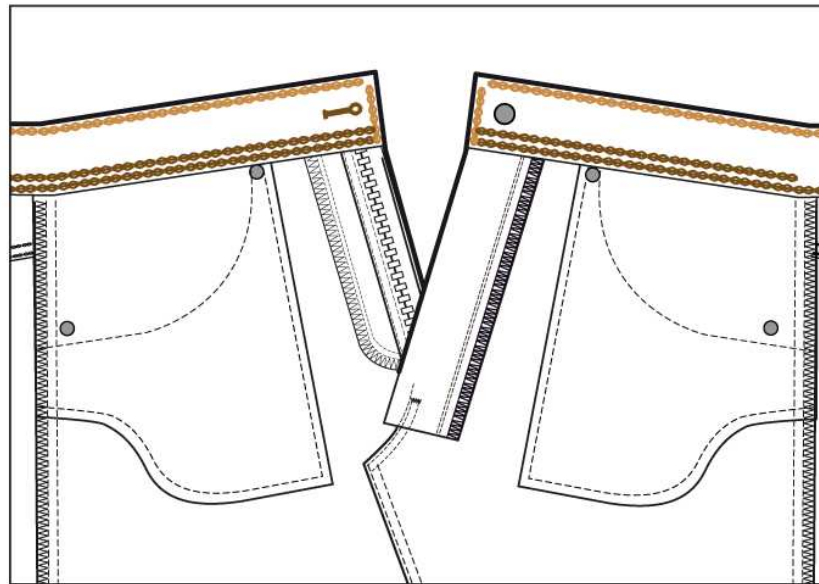

FRONT

INNER MAKING

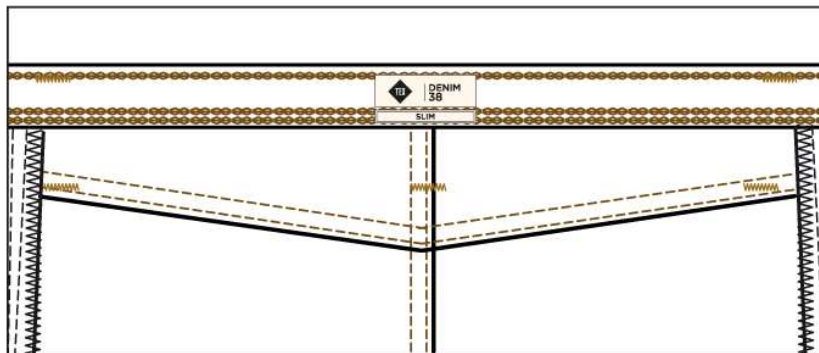

BACK

ESSENTIEL SLIM 5 POCHE

Product Folders Seasonal

Women

Stage of Development

V2 Approved Without Size Set

Season

Summer 2018

Brand

TEX

Buyer

LE GUILLOU Julia

Technical Supervisor

LEMOINE Sandrine

Designer

Pattern Maker

LEMOINE Sandrine

Quality Manager MAI Juliette



groupe carrefour

 groupe carrefour	<b>WOMAN</b> SEASON : <b>SS18</b> DATE : 2016-06-30	Type of product	REF: I766199	FABRIC	Fabric weight	Composition
		ESSENTIEL				AS SWATCH

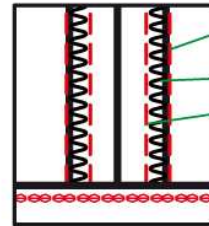
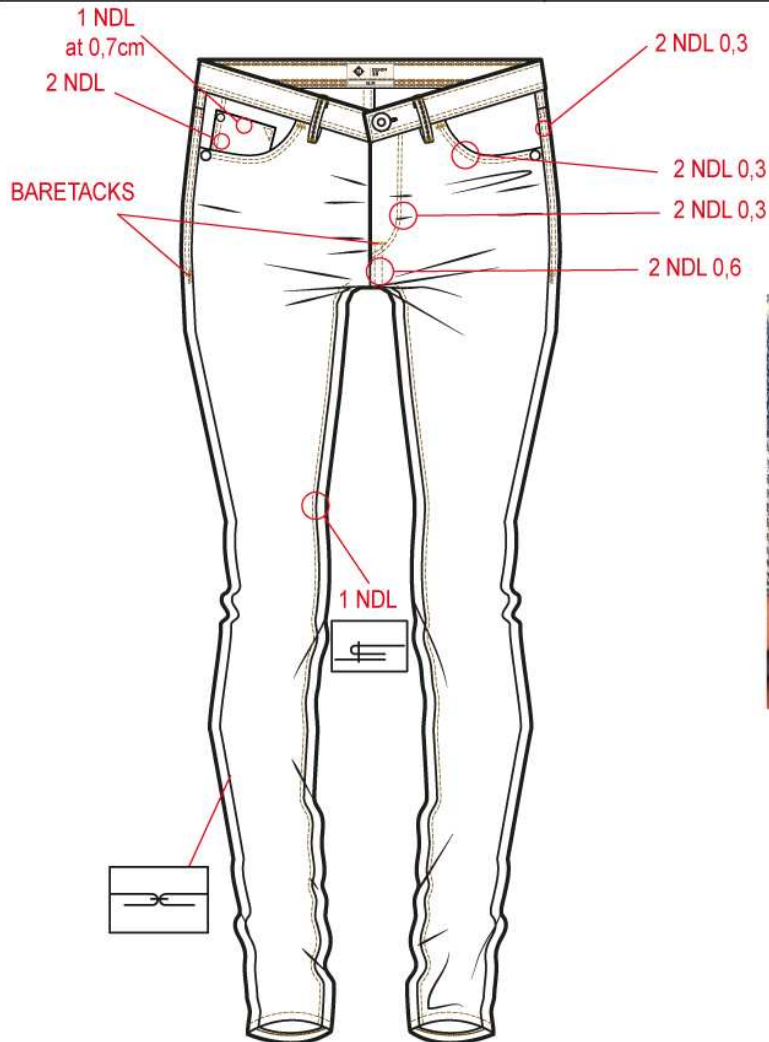

OUTSIDE / OF WHITE (COATS 08168) 2 YARN PER NEEDLE 5 PT/CM  
 LOOP / SAME AS MAIN STICH / YARN SIZE 20  
 INSIDE / OF WHITE (COATS 08168) 2 YARN PER NEEDLE 5 PT/CM

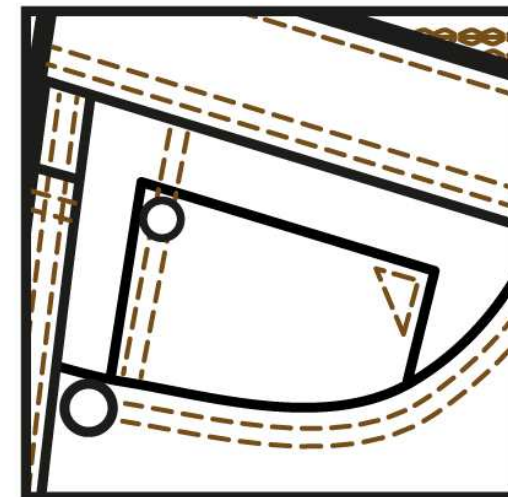

ESSENTIEL SLIM 5 POCHEs

Product Folders Seasonal

Women

Stage of Development

V2 Approved Without Size Set

Season

Summer 2018

Brand

TEX

Buyer

LE GUILLOU Julia

Technical Supervisor

LEMOINE Sandrine

Designer

Pattern Maker

LEMOINE Sandrine

Quality Manager MAI Juliette



groupe carrefour

	<p><b>WOMAN</b></p> <p>SEASON : <b>FW 17</b></p> <p>DATE : 2016-06-30</p>	Type of product	REF:	FABRIC	Fabric weight	Composition
		ESSENTIEL	FW 17-SLIM			AS SWATCH

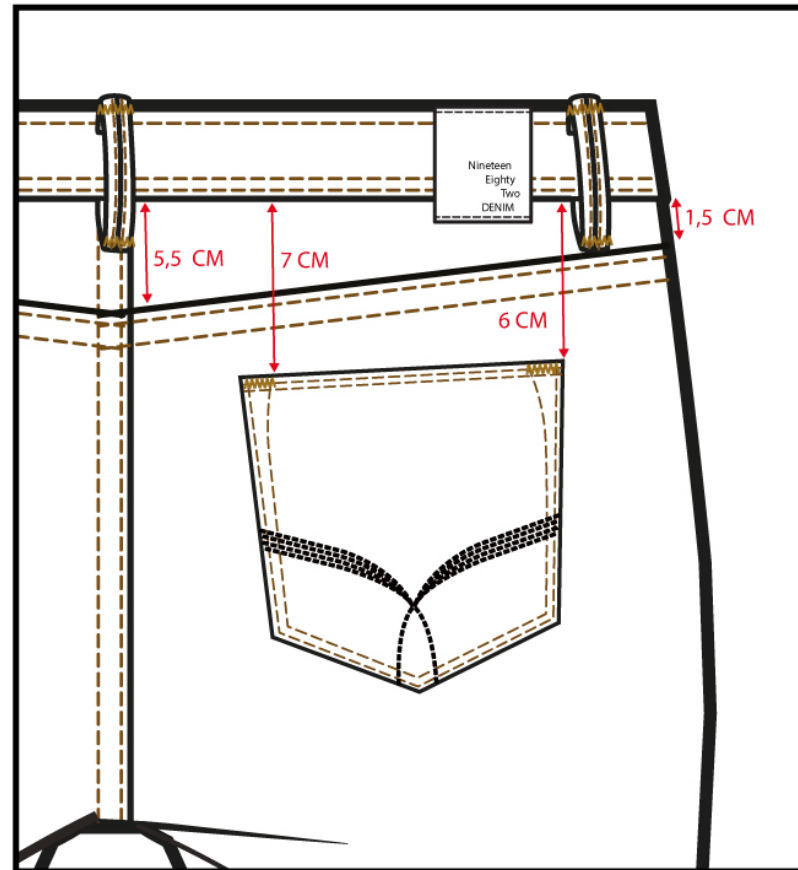
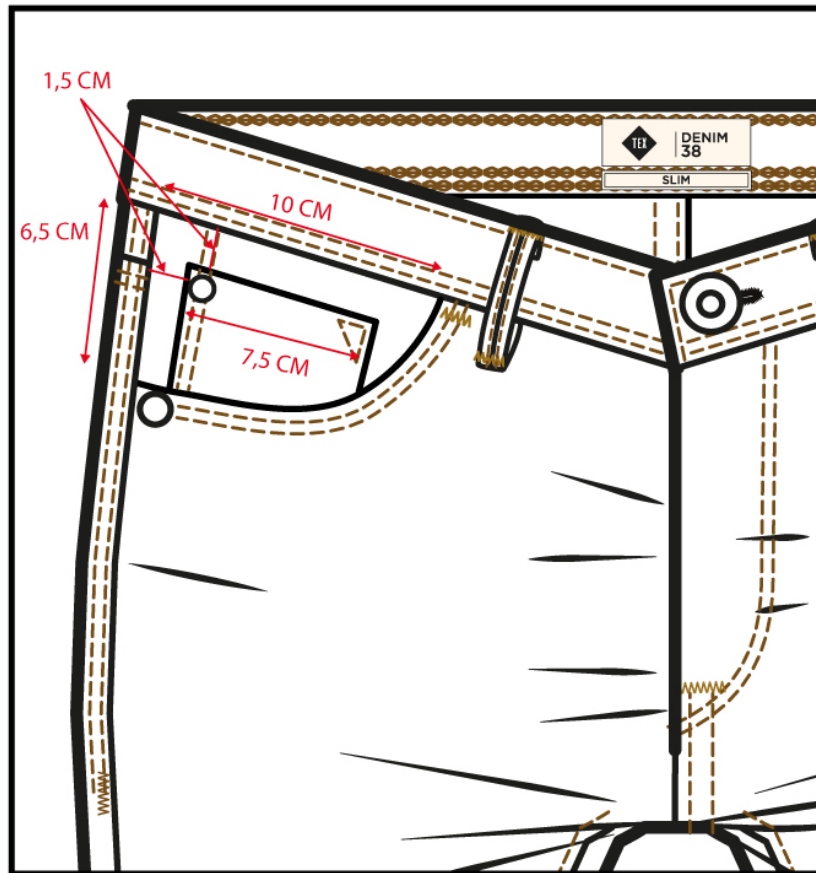

ESSENTIEL SLIM 5 POCHE

	<p><b>WOMAN</b></p> <p>SEASON : <b>SS18</b></p>	Type of product	REF: I766199	FABRIC	Fabric weight	Composition
		ESSENTIEL	SS18-SLIM			AS SWATCH

LEATHER PATCH

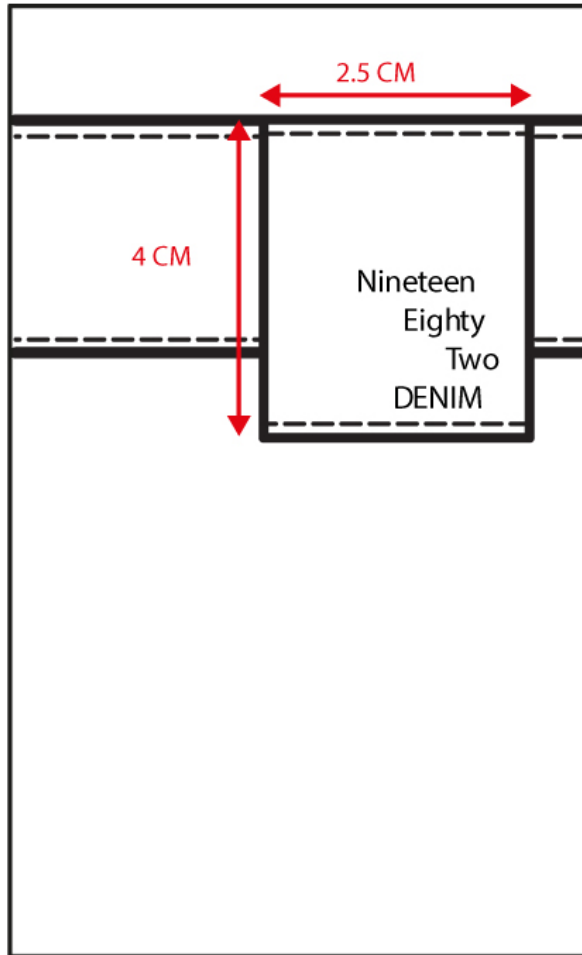

BOUTONS - RIVETS

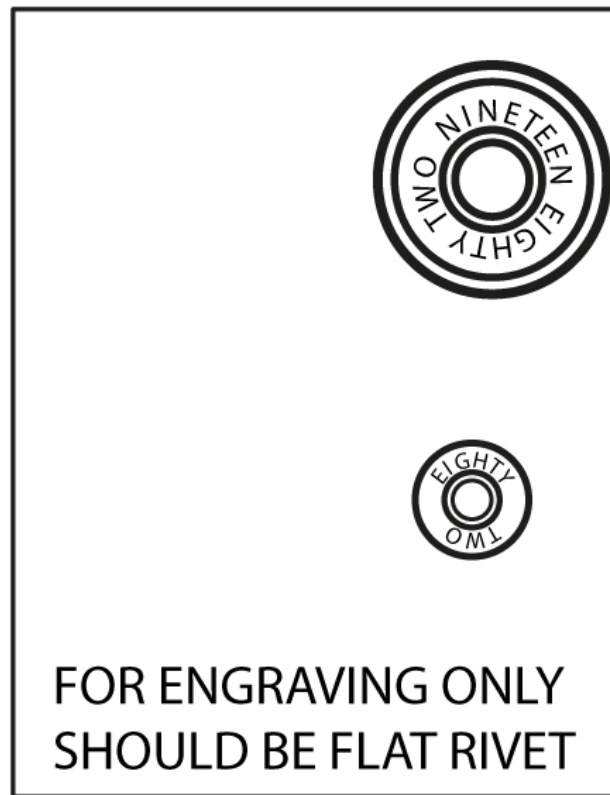

INSIDE BRANDING

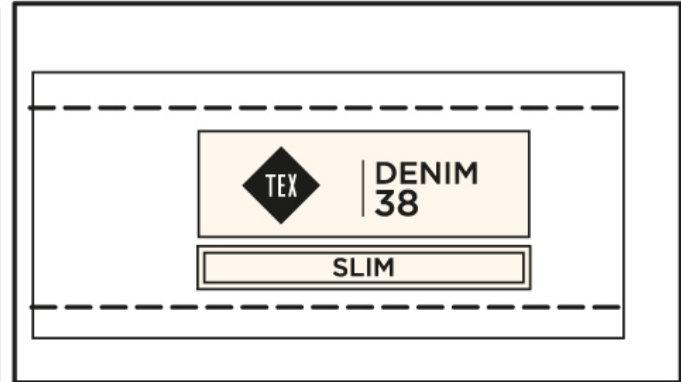



ESSENTIEL SLIM 5 POCHEs

Product Folders Seasonal	Women	Stage of Development	V2 Approved Without Size Set
Season	Summer 2018	Buyer	LE GUILLOU Julia
Brand	TEX	Technical Supervisor	LEMOINE Sandrine
Designer		Pattern Maker	LEMOINE Sandrine
			Quality Manager MAI Juliette



TROUSERS SLIM

Theme: ESSENTIELS

BRAND: TEX FEMME

SEASON: FW17

7 SIZE ADHESIVE BAND  
SIZE ADHESIVE BAND POSITIONING

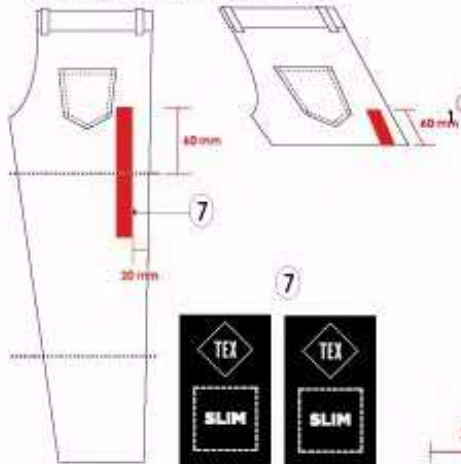

SPECIMEN

DENIM ON HANGER.  
The hanger must be pointing always to the left side.

Please ask the buyer which option to choose.

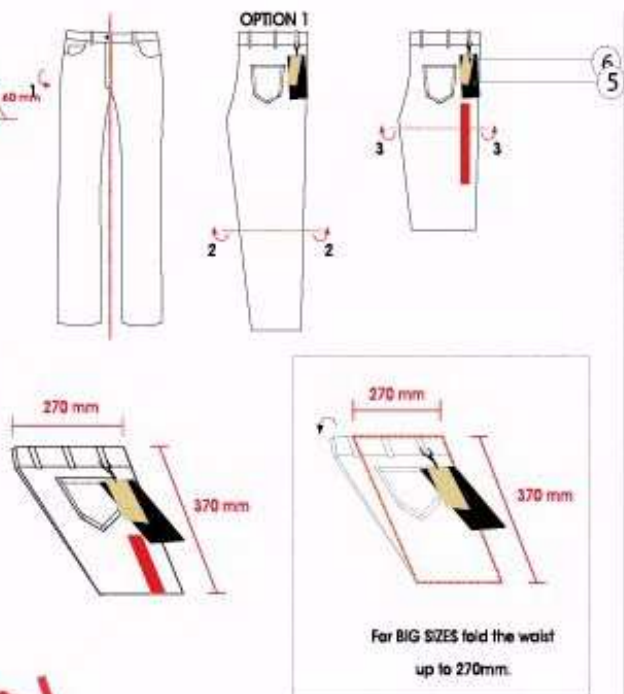

For BIG SIZES fold the waist up to 270mm.

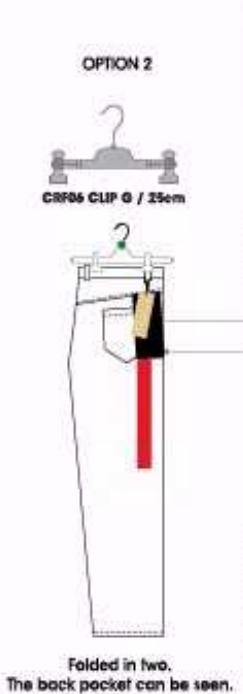

Folded in two. The back pocket can be seen.



SPECIMEN

ESSENTIEL SLIM 5 POCHE

Product Folders Seasonal	Women	Stage of Development	V2 Approved Without Size Set
Season	Summer 2018		
Brand	TEX	Buyer	LE GUILLOU Julia
		Technical Supervisor	LEMOINE Sandrine
Designer		Pattern Maker	LEMOINE Sandrine
			Quality Manager MAI Juliette



TROUSERS SLIM

Theme : ESSENTIELS    BRAND : TEX FEMME    FW17

5 HANGTAG



6 HANG TAG



BRAND INSIDE LABEL

THERMO STICKED LABEL

QUALITY: thermo slicked fabric on the denim  
Printing high definition.

Place it 10 mm from the seamcover.  
It must be ironed at 110°C to be slicked.  
Please put it AFTER all treatments/wash to the garment.

MEASUREMENT : 21 X 65 mm

100% REAL SIZE

Place the label at 30 mm from the sew, on the right side



Attention : different model of woven labels exist.  
Please check attentively each specific manuals.

INSIDE LABELLING.

POSITION OF LABELS: ONE PIECE.

TOP PARTS:

- Place labels 1 and 2 together on side seam, 7cm from the bottom.
- Place label 3 on side seam, 10cm from the bottom.
- Pocket alarm tag must be placed 7cm from labels 1 and 2.



OPTION B



OPTION A

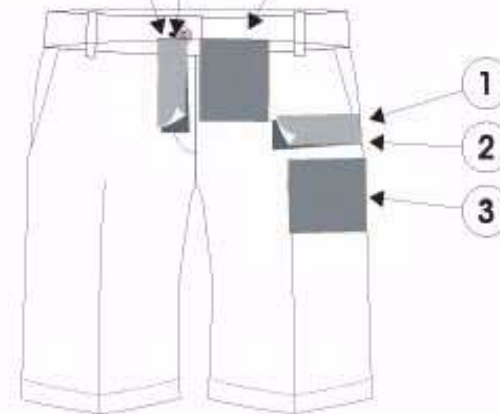

FRONTSIDE WITH TWO COMPOSITION



BACKSIDE



BRAND LABEL



SPECIMEN

ESSENTIEL SLIM 5 POCHEs

Product Folders Seasonal	Women	Stage of Development	V2 Approved Without Size Set
Season	Summer 2018		
Brand	TEX	Buyer	LE GUILLOU Julia
		Technical Supervisor	LEMOINE Sandrine
Designer		Pattern Maker	LEMOINE Sandrine
			Quality Manager MAI Juliette



7-CARE CODE

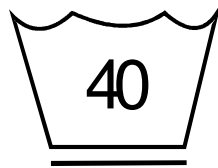

Washing 40°C delicate cycle

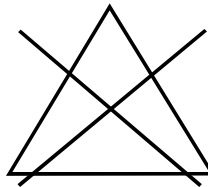

Bleaching Do not bleach

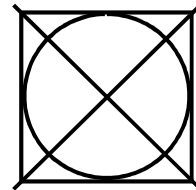

Dry Do not tumble dry

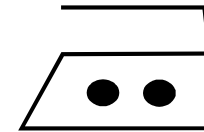

Ironing 150°C (300 F) Medium

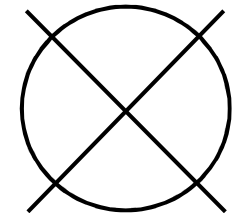

Professional Care Do not dry clean

7-CARE CODE

wash with similar colors  
 lavar con colores similares  
 laver avec couleurs similaires  
 lavare con colori simile  
 wassen met gelijkaardige kleuren

Special mention Wash with similar colors

Wash and iron inside out  
 Laver et repasser sur envers  
 Lavar y planchar al revés  
 Lavare e stirare al contrario  
 Binnenste buiten wassen en strijken

Special mention Wash and iron inside out

ESSENTIEL SLIM 5 POCHE

Product Folders Seasonal Women Stage of Development V2 Approved Without Size Set  
 Season Summer 2018  
 Brand TEX Buyer LE GUILLOU Julia  
 Designer Technical Supervisor LEMOINE Sandrine  
 Pattern Maker LEMOINE Sandrine Quality Manager MAI Juliette



groupe carrefour

 WOMAN  
 SEASON: SS17  
 REF:1775339/40

Type of product: SLIM FIVE POCKET STROUSERS

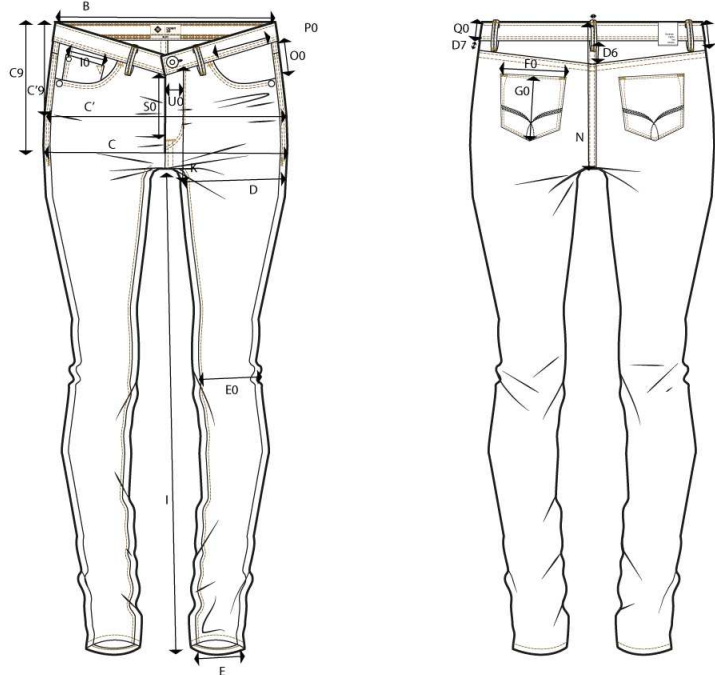

POM	Description	Tol (-)	Tol (+)	32	34	36	[38]	40	42
B	1/2 FLAT WAITSBAND -- STANDARD	-1	1	31	33	35	37	39	41
Q0	WAISTBAND HAIGHT -- STANDARD	-0.5	0.5	3.5	3.5	3.5	3.5	3.5	3.5
C9	HIPS TAKEN AT .. CM WAISTABAND --	-0	0	18.5	19	19.5	20	20.5	21
C	1/2 HIPS -- STANDARD	-1	1	36	38	40	42	44	46
C'9	1/2 SMALL TAKEN AT...CM WB-STANDARD	-0	0	8.5	9	9.5	10	10.5	11
C'	1/2 HIPS-STANDARD	-1	1	33.5	35.5	37.5	39.5	41.5	43.5
K	FRONT RISE WITH WAISTBAND -- SPECIAL	-0.5	0.5	20	20.5	21	21.5	22.2	22.9
N	BACK RISE WITH WAISTBAND -- SPECIAL	-0.5	0.5	32.8	33.5	34.3	35	36	37
D	1/2 THIGH -- STANDARD	-0.5	0.5	23.5	24.5	25.5	26.5	27.5	28.5
I	INSIDE LEG LENGTH -- STANDARD	-1	1	79	79	79	79	79	79
E0	1/2 KNEE -- STANDARD	-0.5	0.5	15	15.5	16	16.5	17.2	17.9
E	1/2 BOTTOM LEG -- STANDARD	-0.5	0.5	11.5	12	12.5	13	13.5	14
P0	POCKET YOKE WIDTH AT WAIST --	-0.5	0.5	9.5	9.5	9.5	10	10	10
O0	POCKET YOKE AT SIDE SEAM HEIGHT --	-0.5	0.5	5.5	5.5	5.5	6	6	6
U0	FLY WIDTH -- STANDARD	-0.5	0.5	3.5	3.5	3.5	3.5	3.5	3.5
S0	FLY OPENING -- STANDARD	-0.5	0.5	7.75	8	8.25	8.5	8.75	9
D6	MIDDLE YOKE BACK HEIGHT	-0.5	0.5	3.7	4	4.2	4.5	4.8	5
D7	SIDE YOKE HEIGHT	-0.5	0.5	2	2	2	2	2	2
F0	BACK POCKET WIDTH	-0.5	0.5	13	13	13	13.5	13.5	14
G0	BACK POCKET HEIGHT	-0.5	0.5	13	13	13	13.5	13.5	14
I0	TICKET POCKET OPENING	-0.5	0.5	6	6	6	6.5	6.5	6.5
R0	BELT LOOP LENGTH	-0.5	0.5	5	5	5	5	5	5
Z6	BELT LOOP WIDTH	-0.5	0.5	1	1	1	1	1	1



ESSENTIEL SLIM 5 POCHE

Product Folders Seasonal Women Stage of Development  
 Season Summer 2018  
 Brand TEX Buyer  
 Designer Technical Supervisor  
 Pattern Maker

V2 Approved Without Size Set  
 LE GUILLOU Julia  
 LEMOINE Sandrine  
 LEMOINE Sandrine Quality Manager MAI Juliette



 WOMAN  
 SEASON: SS17  
 REF:1775339/40

Type of product: SLIM FIVE POCKET STROUSERS

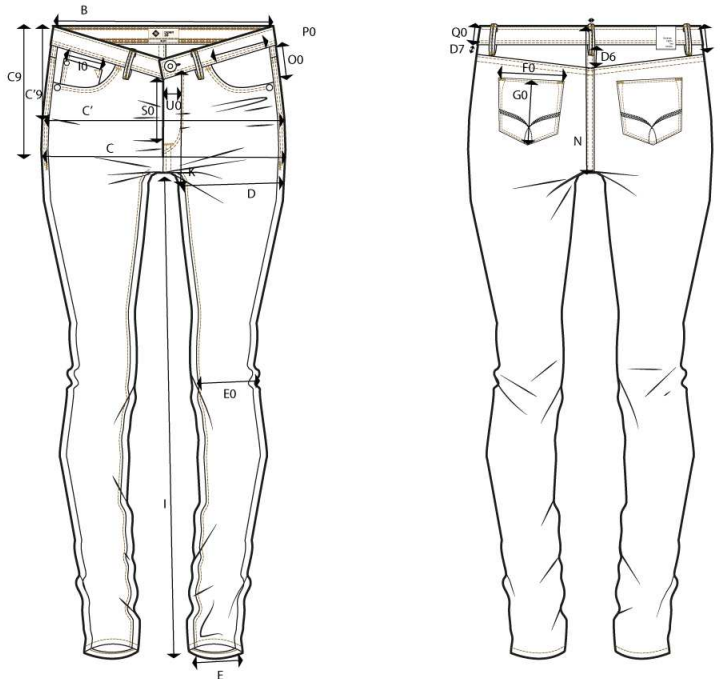

POM	Description	Tol (-)	Tol (+)	44	46	48	50	52	54
B	1/2 FLAT WAITSBAND -- STANDARD	-1	1	43	46	49	52	55	58
Q0	WAISTBAND HAIGHT -- STANDARD	-0.5	0.5	3.5	3.5	3.5	3.5	3.5	3.5
C9	HIPS TAKEN AT .. CM WAISTABAND --	-0	0	21.5	22	22.5	23	23.5	24
C	1/2 HIPS -- STANDARD	-1	1	48	51	54	57	60	63
C'9	1/2 SMALL TAKEN AT...CM WB-STANDARD	-0	0	11.5	12	12.5	13	13.5	14
C'	1/2 HIPS-STANDARD	-1	1	45.5	48.5	51.5	54.5	57.5	60.5
K	FRONT RISE WITH WAISTBAND -- SPECIAL	-0.5	0.5	23.9	25.5	27	28.5	30	31.5
N	BACK RISE WITH WAISTBAND -- SPECIAL	-0.5	0.5	38.5	40.5	42	43.5	45	46.5
D	1/2 THIGH -- STANDARD	-0.5	0.5	30	31.5	33	34.5	36	37.5
I	INSIDE LEG LENGTH -- STANDARD	-1	1	79	79	79	79	79	79
E0	1/2 KNEE -- STANDARD	-0.5	0.5	18.6	19.6	20.6	21.6	22.6	23.6
E	1/2 BOTTOM LEG -- STANDARD	-0.5	0.5	14.5	15.5	16.5	17.5	18.5	19.5
P0	POCKET YOKE WIDTH AT WAIST --	-0.5	0.5	10	10.5	10.5	10.5	11	11
O0	POCKET YOKE AT SIDE SEAM HEIGHT --	-0.5	0.5	6	6.5	6.5	6.5	7	7
U0	FLY WIDTH -- STANDARD	-0.5	0.5	3.5	3.5	3.5	3.5	3.5	3.5
S0	FLY OPENING -- STANDARD	-0.5	0.5	9.25	9.5	9.75	10	10.25	10.5
D6	MIDDLE YOKE BACK HEIGHT	-0.5	0.5	5.3	5.5	5.8	6	6.2	6.5
D7	SIDE YOKE HEIGHT	-0.5	0.5	2	2.5	2.5	2.5	3	3
F0	BACK POCKET WIDTH	-0.5	0.5	14	14.5	14.5	15	15	15.5
G0	BACK POCKET HEIGHT	-0.5	0.5	14	14.5	14.5	15	15	15.5
I0	TICKET POCKET OPENING	-0.5	0.5	7	7	7	7.5	7.5	7.5
R0	BELT LOOP LENGTH	-0.5	0.5	5	5	5	5	5	5
Z6	BELT LOOP WIDTH	-0.5	0.5	1	1	1	1	1	1

ESSENTIEL SLIM 5 POCHE

Product Folders Seasonal Women Stage of Development
Season Summer 2018
Brand TEX Buyer
Designer Technical Supervisor
Pattern Maker

V2 Approved Without Size Set

LE GUILLOU Julia
LEMOINE Sandrine
LEMOINE Sandrine

Quality Manager MAI Juliette



groupecarrefour

Table with columns: POM, Description, Tol (-), Tol (+), 56, 58, 60. Rows include items like B (1/2 FLAT WAITSBAND), Q0 (WAISTBAND HAIGHT), C9 (HIPS TAKEN AT .. CM WAISTABAND), C (1/2 HIPS), C'9 (1/2 SMALL TAKEN AT...CM WB-STANDARD), C' (1/2 HIPS-STANDARD), K (FRONT RISE WITH WAISTBAND), N (BACK RISE WITH WAISTBAND), D (1/2 THIGH), I (INSIDE LEG LENGTH), E0 (1/2 KNEE), E (1/2 BOTTOM LEG), P0 (POCKET YOKE WIDTH AT WAIST), O0 (POCKET YOKE AT SIDE SEAM HEIGHT), U0 (FLY WIDTH), S0 (FLY OPENING), D6 (MIDDLE YOKE BACK HEIGHT), D7 (SIDE YOKE HEIGHT), F0 (BACK POCKET WIDTH), G0 (BACK POCKET HEIGHT), I0 (TICKET POCKET OPENING), R0 (BELT LOOP LENGTH), Z6 (BELT LOOP WIDTH).



ESSENTIEL SLIM 5 POCHEs

Product Folders Seasonal	Women	Stage of Development	V2 Approved Without Size Set
Season	Summer 2018		
Brand	TEX	Buyer	LE GUILLOU Julia
		Technical Supervisor	LEMOINE Sandrine
Designer		Pattern Maker	LEMOINE Sandrine
			Quality Manager MAI Juliette



groupecarrefour

	<p><b>REFERENCE:1766199</b></p> <p>DATED ON THE: 18 05 2017(color grey light for fitting)</p> <p>TRADING: BANGLADESH</p> <p>SUPPLIER: TUSUKA</p> <p>FABRIC COMPOSITION: 69%CO-23%PES-7%VIS-1%FA</p>	<p>DATE: 01 06 2017</p>
	<p>SAMPLE COMMENTS</p> <p>THIS IS MY COMMENTS CONCERNING THE 1ST SAMPLE</p> <p>1-MAKE THE LENGHT OF 79 CM</p> <p>2-IMPROVE THE BACK POCKET POSITION AND MAKING PUT THEM PARRALLELL TO WAISTBAND</p> <p>3-IMPROVE THE BACK YOKE MAKING TO BE REGULAR AND STRAIGHT</p> <p>4-CANCEL THE BACK POCKET TOPSTITCHINGS</p> <p>RECTIFY YOUR PATTERN SIZE 38 AND SEND US A SSS S36 38 40 46</p> <p>REGARDS SANDRINE</p>	

## ESSENTIEL SLIM 5 POCHEs

Product Folders Seasonal	Women	Stage of Development	V2 Approved Without Size Set
Season	Summer 2018		
Brand	TEX	Buyer	LE GUILLOU Julia
		Technical Supervisor	LEMOINE Sandrine
Designer		Pattern Maker	LEMOINE Sandrine
			Quality Manager MAI Juliette



groupecarrefour

	<b>REFERENCE:I766199</b> DATED ON THE: 19 06 2017(color grey light for fitting) TRADING: BANGLADESH SUPPLIER: TUSUKA FABRIC COMPOSITION: 69%CO-23%PES-7%VIS-1%EA	DATE: 05 07 2017  SSS COMMENTS
	THIS IS MY COMMENTS CONCERNING THE SSS  SSS IS OK FITTING UNDER CONDITION TO RESPECT MEASUREMENTS FROM SPEC AND TO NOT STRECH THE WAISTBAND  SEND US A PPS SIZE 38 ASAP WITH CORRECT BRANDING AND PACKAGING  REGARDS SANDRINE	

ESSENTIEL SLIM 5 POCHEs

Product Folders Seasonal Women Stage of Development V2 Approved Without Size Set  
 Season Summer 2018  
 Brand TEX Buyer LE GUILLOU Julia  
 Designer Technical Supervisor LEMOINE Sandrine  
 Pattern Maker LEMOINE Sandrine Quality Manager MAI Juliette



groupe carrefour



Company: 63- WOMAN  
 Size Class: SIZE CLASS  
 Product Type: 61- Pants/Legging  
 Factory: TUSUKA FASHIONS  
 Measurer: RAHMANF  
 DT Requested: 22 JUN 2017  
 Lot Number: 01  
 Color: Greylt  
 Total Units: 01

Selected Range: 32, 34, 36, 38, 40, 42, 44, 46, 48, 50, 52, 54, 56, 58, 60

P O M	Description	Tol (-)	Tol (+)	Size 36	Sample 1	Size 38	Sample 1	Size 46	Sample 1				
B	1/2 FLAT WAITSBAND -- STANDARD	-1	1	35	35.5	37	36.5	46	46				
Q0	WAISTBAND HAIGHT -- STANDARD	-0.5	0.5	3.5	3.5	3.5	3.3	3.5	3.5				
C9	HIPS TAKEN AT .. CM WAISTABAND -- STANDARD	-0	0	19.5	<195>	20	20	22	22				
C	1/2 HIPS -- STANDARD	-1	1	40	40	42	41.5	51	50				
C'9	1/2 SMALL TAKEN AT...CM WB-STANDARD	-0	0	9.5	9.5	10	10	12	12				
C'	1/2 HIPS-STANDARD	-1	1	37.5	37.5	39.5	39	48.5	48.5				
K	FRONT RISE WITH WAISTBAND -- SPECIAL	-0.5	0.5	21	21	21.5	22	25.5	25.9				
N	BACK RISE WITH WAISTBAND -- SPECIAL	-0.5	0.5	34.3	<35>	35	34.5	40.5	40.5				
D	1/2 THIGH -- STANDARD	-0.5	0.5	25.5	25	26.5	26.5	31.5	31				
I	INSIDE LEG LENGTH -- STANDARD	-1	1	79	78	79	78	79	78.5				
E0	1/2 KNEE -- STANDARD	-0.5	0.5	16	16	16.5	16	19.6	19.6				
E	1/2 BOTTOM LEG -- STANDARD	-0.5	0.5	12.5	12.5	13	13	15.5	15.5				
P0	POCKET YOKE WIDTH AT WAIST -- STANDARD	-0.5	0.5	9.5	9	10	10	10.5	10.1				
O0	POCKET YOKE AT SIDE SEAM HEIGHT -- STANDARD	-0.5	0.5	5.5	5.5	6	6	6.5	6.5				
U0	FLY WIDTH -- STANDARD	-0.5	0.5	3.5	3.5	3.5	3.5	3.5	3.5				
S0	FLY OPENING -- STANDARD	-0.5	0.5	8.25	8.25	8.5	8.5	9.5	9.5				
D6	MIDDLE YOKE BACK HEIGHT	-0.5	0.5	4.2	4	4.5	4.5	5.5	5.2				
D7	SIDE YOKE HEIGHT	-0.5	0.5	2	2	2	2	2.5	2.5				

ESSENTIEL SLIM 5 POCHEs

Product Folders Seasonal      Women      Stage of Development      V2 Approved Without  
Season      Summer 2018           Size Set  
Brand      TEX      Buyer      LE GUILLOU Julia  
           Technical Supervisor      LEMOINE Sandrine  
Designer           Pattern Maker      LEMOINE Sandrine      Quality Manager MAI Juliette



Selected Range: 32, 34, 36, 38, 40, 42, 44, 46, 48, 50, 52, 54, 56, 58, 60

P O M	Description	Tol (-)	Tol (+)	Size 36	Sample 1	Size 38	Sample 1	Size 46	Sample 1				
F0	BACK POCKET WIDTH	-0.5	0.5	<b>13</b>	13	<b>13.5</b>	13.5	<b>14.5</b>	14.2				
G0	BACK POCKET HEIGHT	-0.5	0.5	<b>13</b>	13	<b>13.5</b>	13.5	<b>14.5</b>	14.7				
I0	TICKET POCKET OPENING	-0.5	0.5	<b>6</b>	6	<b>6.5</b>	6	<b>7</b>	6.7				
R0	BELT LOOP LENGTH	-0.5	0.5	<b>5</b>	5	<b>5</b>	5	<b>5</b>	5				
Z6	BELT LOOP WIDTH	-0.5	0.5	<b>1</b>	1	<b>1</b>	1	<b>1</b>	1				

ESSENTIEL SLIM 5 POCHEs

Product Folders Seasonal	Women	Stage of Development	V2 Approved Without Size Set
Season	Summer 2018		
Brand	TEX	Buyer	LE GUILLOU Julia
		Technical Supervisor	LEMOINE Sandrine
Designer		Pattern Maker	LEMOINE Sandrine      Quality Manager MAI Juliette



POM Comments

POM	Sample 1 Description	Eval Size 38	Sample 1	Delta 1	Revised Spec
B	1/2 FLAT WAITSBAND -- STANDARD	38.5	<37>	-1.5	37
Q0	WAISTBAND HAIGHT -- STANDARD	3.5	3.5	0	
C9	HIPS TAKEN AT .. CM WAISTABAND -- STANDARD	20	20	0	
C	1/2 HIPS -- STANDARD	42	42	0	
C'9	1/2 SMALL TAKEN AT...CM WB-STANDARD	10	10	0	
C'	1/2 HIPS-STANDARD	40	39.5	-0.5	39.5
K	FRONT RISE WITH WAISTBAND -- SPECIAL	21.5	21	-0.5	
N	BACK RISE WITH WAISTBAND -- SPECIAL	35	35.5	0.5	
D	1/2 THIGH -- STANDARD	26.5	26	-0.5	
I	INSIDE LEG LENGTH -- STANDARD	82	81	-1	79
E0	1/2 KNEE -- STANDARD	16.5	16.5	0	
E	1/2 BOTTOM LEG -- STANDARD	13	13	0	
P0	POCKET YOKE WIDTH AT WAIST -- STANDARD	10	9.5	-0.5	
O0	POCKET YOKE AT SIDE SEAM HEIGHT -- STANDARD	6	5.5	-0.5	
U0	FLY WIDTH -- STANDARD	3.5	3.5	0	
S0	FLY OPENING -- STANDARD	8.5	8	-0.5	
D6	MIDDLE YOKE BACK HEIGHT	4.5	4	-0.5	
D7	SIDE YOKE HEIGHT	2	2	0	
F0	BACK POCKET WIDTH	13.5	13	-0.5	
G0	BACK POCKET HEIGHT	13.5	13	-0.5	
I0	TICKET POCKET OPENING	6.5	6	-0.5	
R0	BELT LOOP LENGTH	5	4.5	-0.5	
Z6	BELT LOOP WIDTH	1	1	0	

## ESSENTIEL SLIM 5 POCHEs

Product Folders Seasonal	Women	Stage of Development	V2 Approved Without Size Set	
Season	Summer 2018			
Brand	TEX	Buyer	LE GUILLOU Julia	
		Technical Supervisor	LEMOINE Sandrine	
Designer		Pattern Maker	LEMOINE Sandrine	Quality Manager MAI Juliette



## EXCLUSIVITY CLAUSES

GARMENTS, ACCESSORIES AND PACKAGING SHOULD BE CONFORM TO BUYER 's SPECIFICATIONS

THE SUPPLIER MUST AGREE WITH THE QUALITY PROCESS  
A PART OF THE QUALITY COSTS IS PAID BY THE SUPPLIER

THEY WILL BE EXCLUSIVELY FOR CARREFOUR 's STORES

DATE :

SUPPLIER 's SIGNATURE

COMPANY 's STAMP