

Water pollution & Treatment Plant

Dr. Nizam Uddin



Water pollution

“Any human activity that impairs the use of water as a resource may be called water pollution. With exploding population and increasing industrialization and urbanization, water pollution by agriculture, municipal and industrial sources has become a major concern for the welfare of mankind”.

Introduction: Water is essential for the survival of any form of life. On an average, a human being consumes about 2 liters of water everyday. Water accounts for about 70% of the weight of human body. About 80% of the earth's surface is covered by water. Out of the estimated 1011 million km³ of the total water present on earth, only 33,400 m³ of water is available for drinking, agriculture, domestic and industrial consumption. The rest of the water is locked up in oceans as salt water, polar ice-caps and glaciers and underground. Owing to increasing industrialization on one hand and exploding population on the other, the demands of water supply have been increasing tremendously. Moreover, considerable part of this limited quantity of water is polluted by sewage, industrial wastes and wide array of synthetic chemicals. The menace of water-borne diseases and epidemics still threatens the well-being of population, particularly in under-developed and developing countries. Thus, the quality as well as the quantity of clean water supply of vital significance FOE the welfare of mankind.

Classification of water pollutants

The various types of water pollutants can be broadly classified into the following five major categories:

1. **Organic pollutants**
2. **Inorganic pollutants**
3. **Suspended solids and sediments**
4. **Radioactive materials**
5. **Heat**

1. Organic pollutants: The organic pollutants may be further categorized as follows:

a. ***Oxygen-demanding wastes.*** These include domestic and animal sewage, bio-degradable organic compounds and wastes from food processing plants, meat-packing plants, slaughter-houses, paper and pulp mills, tanneries etc., as well as agriculture run-off. All these wastes undergo degradation and decomposition by bacterial activity in presence of dissolved oxygen (D.O). This results in rapid depletion of D.O. from the water, which is harmful to aquatic organisms. **The optimum D.O. in natural waters is 4-6 ppm, which is essential for supporting aquatic life. Any decrease in this D.O. value is an index of pollution by the above mentioned oxygen demanding wastes. Many aquatic organisms cannot survive at lower D.O. levels in water.**

b. ***Diseases-causing wastes***. These include **pathogenic microorganisms** which may enter the water along with sewage and other wastes and may cause tremendous damage to public health. These microbes, comprising mainly of viruses and bacteria, can cause dangerous water-borne diseases such as **cholera, typhoid, dysentery, polio and infectious hepatitis** in humans. Hence, disinfection is the primary step in water pollution control.

c. ***Synthetic organic compounds***. These are the man-made materials such as **synthetic pesticides, synthetic detergents, food additives, pharmaceuticals, synthetic fibers other industrial chemicals** etc. these chemicals may enter the hydrosphere either by spillage during transport and use or by intentional or accidental release of wastes from their manufacturing establishments. Most of these chemicals are potentially toxic to plants, animals and humans. Some bio-refractory organics such as aromatic chlorinated hydrocarbons may cause offensive colors, odors and tastes in water, even when present in traces and makes the water unacceptable from aesthetic point of view. Non-degradable chemicals, such as alkyl benzene sulphonate from synthetic detergents often lead to persistent foams. Volatile substances, such as alcohols, aldehydes, ethers and gasoline may cause explosion in sewers.

d. ***Sewage and agricultural run-off.*** Sewage and run-off from agricultural lands supply **plant nutrients, which may stimulate the growth of algae and other aquatic weeds in the receiving water body.** This unwieldy plant-growth results in the degradation of the value of the body, intended for recreational and other uses. Further, the water body loses all its **D.O.** in the long run due to the natural biological process of **eutrophication** and ends up as a **dead pool of water.**

e. ***Oil pollution*** may take place because of oil spills from cargo oil tankers on the seas, losses during off-shore exploration and production of oil, accidental fires in ships and tankers, accidental or intentional oil slicks and leakage from oil pipe-lines, crossing waterways and reservoirs. Oil pollution results in reduction of light transmission through surface waters, thereby reducing photosynthesis by marine plants. Further, it reduces the D.O. in water and endangers water birds, costal plants and animals. Thus, oil pollution leads to unsightly and hazardous conditions which are deleterious to marine-life and sea-food. Oil pollution in seas has been increasing in recent years due to the increase in oil-based technologies, massive oil slicks during international hostilities.

2. Inorganic pollutants: Inorganic pollutants comprise of mineral acids, inorganic salts, finely divided metals or metal compounds, trace elements, cyanides, sulphates, nitrates, organ metallic compounds and complexes of metals with organics present in natural waters. The metal-organic interactions involve natural organic species, such as fulvic acids and synthetic organic species, such as EDTA. These interactions are influenced by or influence redox equilibria, acid-base reactions, colloid formation and reactions involving microorganisms in water. Algal growths in water and metal toxicity in aquatic ecosystems are also influenced by these interactions.

Various metal and metallic compounds released from anthropogenic activities add up to their natural background levels in water. Some of these trace metals play essential roles in biological processes but at higher concentrations, they may be toxic to biota.

The most toxic among the trace elements are the heavy metals, such as Hg, Cd and Pb and metalloids, such as As, Sb and Se. The heavy metal have a great affinity for sulphur and attack the -SH bonds in enzymes, thereby immobilizing the letter. Protein carboxylic acid groups (-COOH) and amino-groups (-NH₂) may also be attacked by the heavy metal ions. The heavy metals that may be bound to the cell membranes interfere with the transport phenomena across the cell wall. Heavy metal tends to precipitate phosphate bio compounds or catalyses their decomposition. Water pollution by heavy metals occurs mostly due to street dust, domestic sewage and industrial effluents.

Polyphosphates from detergents serve as algal nutrients and thus are significant as water pollutants.

3. Suspended solids and sediments:

Sediments are mostly contributed by soil erosion by natural processes, agricultural development, and strip mining and construction activities. Suspended solids in water mainly comprise of silt, sand and minerals eroded from the land. Soil erosion by water, wind and other natural forces are very significant for tropical countries NPK fertilizers are washed away into the sea. This erosion leads to qualitative and quantitative degradation of soil in land area. Thus, soil may be getting removed from agricultural land to areas where it is not at all required, such as water reservoirs. Soil particles eroded by running water ultimately find their way into water reservoirs and such a process called siltation. Reservoirs and dams are filled with soil particles and other solid materials, because of siltation. This reduces the water storage capacity of the dams and reservoirs and thus shortens their life. Apart from the filling up of the reservoirs and harbors, the suspended solids present in water bodies may block the sunlight required for photosynthesis by the bottom vegetation. This may also smother shell fish, corals and other bottom life forms. Deposition of solids in quiescent stretches of streams impairs the normal aquatic life in the streams. Further sludge blankets containing organic solids decompose, leading to anaerobic conditions and formation of obnoxious gases. The tremendous problem of soil erosion can be controlled by proper cultivation practices and efficient soil and forest management techniques.

The organic matter content in sediments is generally higher than that in soils. Sediments and suspended particles exchanges cations with the surrounding aquatic medium and act as repositories for trace metals such as Cu, Co, Ni, Mn, Cr, and Mo. Suspended solids such as silt and coal may injure the gills of the fish and cause asphyxiation.

4. Radioactive materials:

The radioactive water pollutants may originate from the following anthropogenic activities:

- a. Mining and processing of ores e.g., Uranium tailings.
- b. Increasing use of radioactive isotopes in research, agricultural, industrial and medical (diagnostic as well as therapeutic) applications, e.g., I^{131} , P^{32} , Co^{60} , Ca^{45} , S^{35} and Cs^{137} .
- c. Radioactive materials from nuclear power plants and nuclear reactors, e.g., Sr^{90} , Cs^{137} , Pu^{248} , Am^{241} .
- d. Radioactive materials from testing and use of nuclear weaponry, e.g., Sr^{90} , Cs^{137} .

The radioactive isotopes found in water include Sr^{90} , I^{131} , Cs^{137} , Cs^{141} , Co^{60} , Mn^{54} , Fe^{55} , K^{40} , Ra^{226} .

These radioactive isotopes are toxic to life-forms. For instance, Sr^{90} , which emanates from testing of nuclear weapons, accumulates in bones and teeth and causes serious disorders in human beings. The maximum permissible levels of Sr^{90} in water is 10 pico curies per liter. (1 pico curie= 10^{-12} curie)

5. Heat :

Waste heat is produced in all processes in which heat is converted into mechanical work. Thus, considerable thermal pollution results from thermal power plant, particularly the nuclear-power-based electricity generating plants. In such industries, where the water is used as a coolant, the waste hot water is returned to the original water bodies. Hence the temperature of water bodies increases. These rises in temperature decrease the D.O. content of water, which adversely affects the aquatic life. Moreover any rise in temperature may increase the susceptibility of aquatic biota to the toxic effects of some chemicals, such as methyl mercury and some polycyclic aromatic hydrocarbons. Reduction of D.O. in water may alter the spectrum of organisms that can adopt to live at that temperature and that D.O. level. Suspended solids in water may also cause bad odors and tastes and also may promote conditions favorable for growth of pathogenic bacteria.

If the pollutant concentration in the receiving waters is not within the acceptable limits, adequate steps must be taken to minimize or remove them by suitable treatment techniques e.g., sedimentation, filtration, biological oxidation, chemical precipitation or adsorption by activated carbon.

Characterization of waste waters :

Waste waters are characterized on the basis of various physical, chemical and biological characteristics apart from flow data details:

1. Physical characteristics. Color, odor, dissolved oxygen, insoluble substances (settle-able solids, suspended solids), corrosive properties, radio-activity, temperature range, formability etc.

2. Chemical characteristics. Chemical oxygen demand, pH, acidity or alkalinity, hardness, total Carbon, total dissolved solids, chlorine demand, known organic and inorganic components such as Cl, S²⁻, SO₄²⁻, N, P, Pb, Hg, Cr, As, surfactants, phenols, hydrocarbons oils and greases.

3. Biochemical characteristics. Biochemical oxygen demand, presence of pathogenic bacteria etc., and toxicity to man, aquatic organisms, plants and other particular waste.

The actual methods used for the treatment of a waste depend upon the characteristics of the particular waste.

National standard (waste discharge quality standard for industry)

Parameter	Unit	Inland surface water	Public Sewer secondary treatment plant	Irrigated land
Ammoniacal Nitrogen (N molecule)	mg/l	50	75	75
Ammonia (free ammonia)	mg/l	5	5	15
Arsenic	mg/l	0.2	0.5	0.2
BOD5 200C	mg/l	50	250	100
Boron (B)	mg/l	2	2	2
Cadmium (Cd)	mg/l	0.05	0.5	0.5
Chloride (Cl ⁻)	mg/l	600	600	600
Chromium (total Cr)	mg/l	0.5	1.0	1.0
COD	mg/l	200	400	400
Chromium (hexavalent Cr)	mg/l	0.1	1.0	1.0
Copper (Cu)	mg/l	0.5	3.0	3.0
Dissolved Oxygen (DO)	mg/l	4.5-8	4.5-8	4.5-8

Effluent treatment plant

Parameter	Unit	Inland Surface water	Public Sewer secondary treatment	Irrigated Land
Electrical Conductivity	micro mho/cm	1200	1200	1200
Total Dissolved Solids (TDS)	mg/l	2100	2100	2100
Fluoride (F)	mg/l	7	15	10
Sulfide (S)	mg/l	1	2	2
Iron (Fe)	mg/l	2	2	2
Total Kjeldahl Nitrogen (N)	mg/l	100	100	100
Lead (Pb)	mg/l	0.1	0.1	0.1
Manganese (Mn)	mg/l	5	5	5
Mercury (Hg)	mg/l	0.01	0.01	0.01
Nickel (Ni)	mg/l	1.0	1.0	1.0
Nitrate (N molecule)	mg/l	10.0	Undetermined	10.0
Oil & grease	mg/l	10	20	10
Phenol compounds (C ₆ H ₅ OH)	mg/l	1.0	5	1
Dissolved Phosphorus (P)	mg/l	8	8	10
Radioactive materials:	As determined by Bangladesh Atomic Energy Commission			
pH		6-9	6-9	6-9
Selenium (Se)	mg/l	0.05	0.05	0.05
Zn (Zn)	mg/l	5.0	10.0	10.0
Temperature	Centigrade			
Summer	0C	40	40	40
Winter	0C	45	45	45
Total Suspended Solid (TSS)	mg/l	150	500	200
Cyanide (CN)	mg/l	0.1	2.0	0.2

Characteristic of waste water of typical food processing

pH	8-14
BOD	400-600 PPM
COD	800-1200 PPM
TSS	200-500 PPM
TDS	3000-6000 PPM
OIL & GREASE	30-60 PPM
COLOR	Dark mixed
TEMPERATURE	Up to 600C

What national or international standards must you comply with?

What volume of effluent do you have? What chemicals does it contain? At what concentrations? e.g. 30m³/hour with COD of 500ppm, and pH of 11.5
Do you plan to increase production? Will this increase the amount of effluent to be treated?

How much can you afford to spend on constructing an ETP?

How much can you afford to spend on running an ETP?

How much land do you have available, or can you buy, on which to build the ETP?

Which ETP expert or designer should be used?

What type of plant will best suit your requirements? (the answers that you give to the above questions will help you and the designers to decide this).

What capacity do you have in your factory to manage the ETP? Do you need to hire more staff or train existing staff?

- **Biological treatment**

The basic units needed for biological treatment are: screening; an equalization unit; a pH control unit; an aeration unit; and a settling unit. A sludge dewatering unit may also be included. Biological treatment plants require the presence of microorganisms that are adapted to degrade the components of the effluent to be treated. Textile industry waste will not contain suitable microorganisms so these must be added to the ETP when it is set up. Traditionally in South Asia cow dung is used as a source of microorganisms. While it may be useful to use cow dung it is unlikely to be the best source of microbes for treatment of textile waste. If possible new reactors (either activated sludge or fixed film systems) should be set up using activated sludge from an existing ETP, preferably one treating a similar waste. If this is not possible polluted river water is likely to be a good source of suitable microorganisms and can be used together with cow dung or activated sludge. It is likely to take several months for the microbial population to establish itself and successful treatment to result.

Table: Biological Treatment processes

Treatment Processes	Definition
Suspended-growth processes e.g. activated sludge	The microorganisms are maintained in suspension in the liquid
Attached-growth processes or fixed-film processes	The microorganisms are attached to some inert medium such as rock or inert plastics
Combined processes	A combination of suspended-growth and fixed-film

- **Output quality**

Evidence shows that output quality from biological treatment can satisfy the national standards for most of the required parameters except color. According to Metcalf & Eddy (2003) a properly designed Biological ETP can efficiently satisfy BOD, pH, TSS, oil and grease requirements. However, as already mentioned, the compounds in industrial wastewater may be toxic to the microorganisms so pretreatment may be necessary. Similarly most dyes are complex chemicals and are difficult for microbes to degrade so there is usually very little color removal.

WATER TREATMENT PLANT

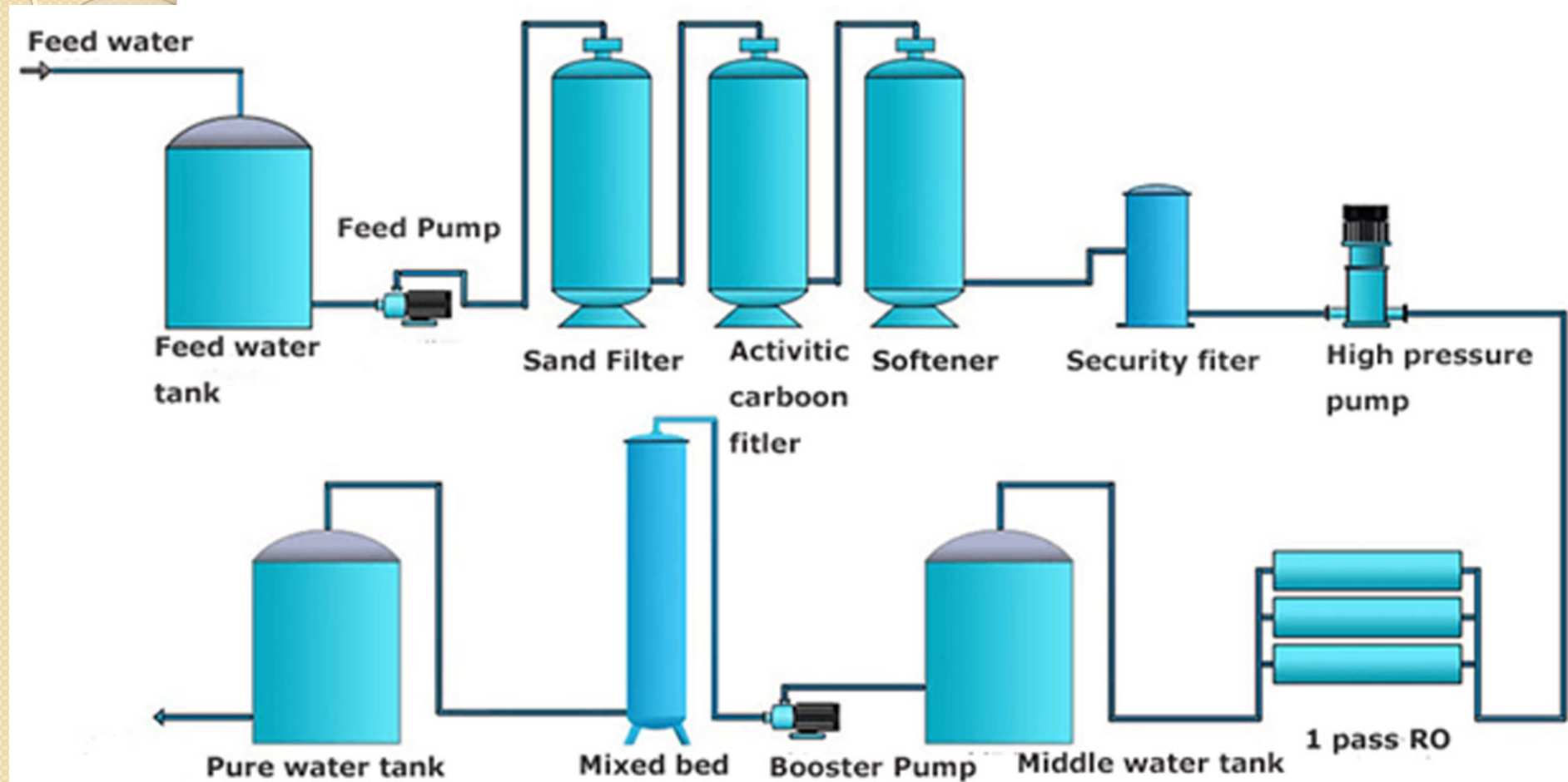

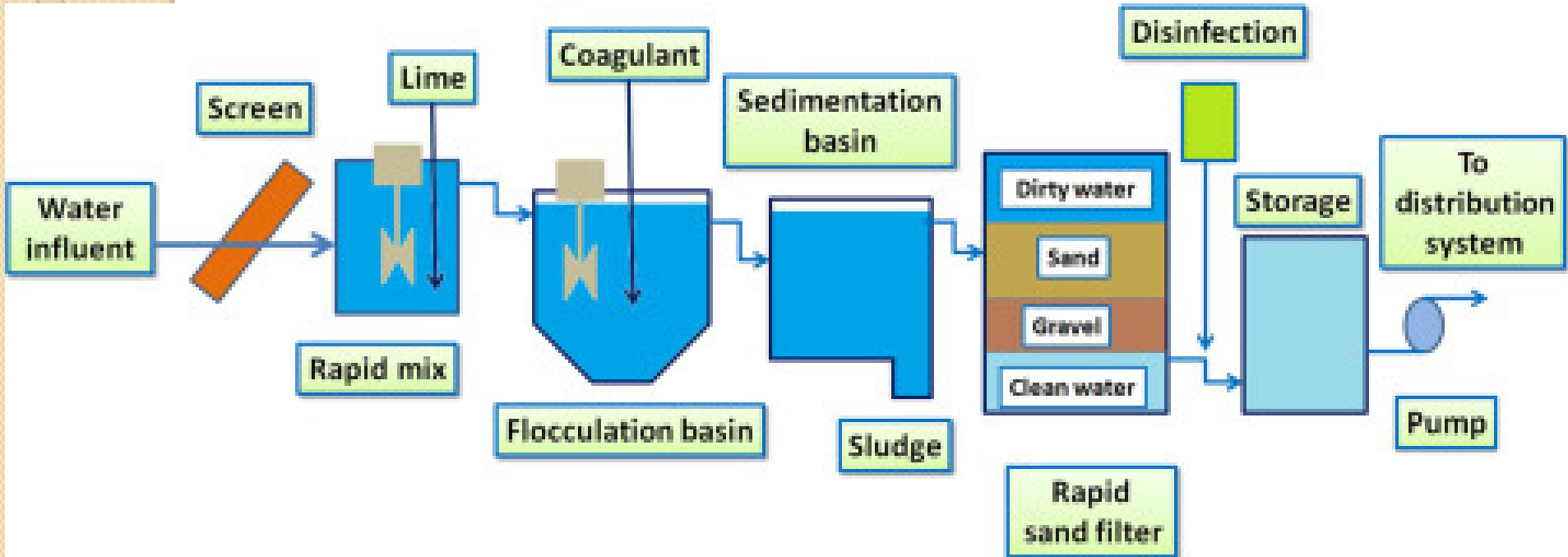
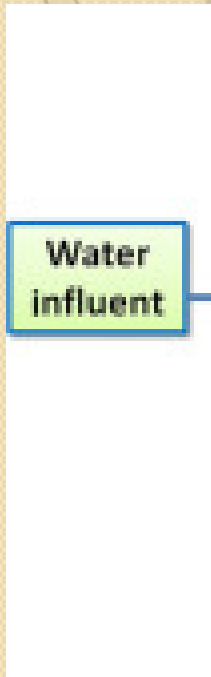

Effluent treatment plant (Biological)

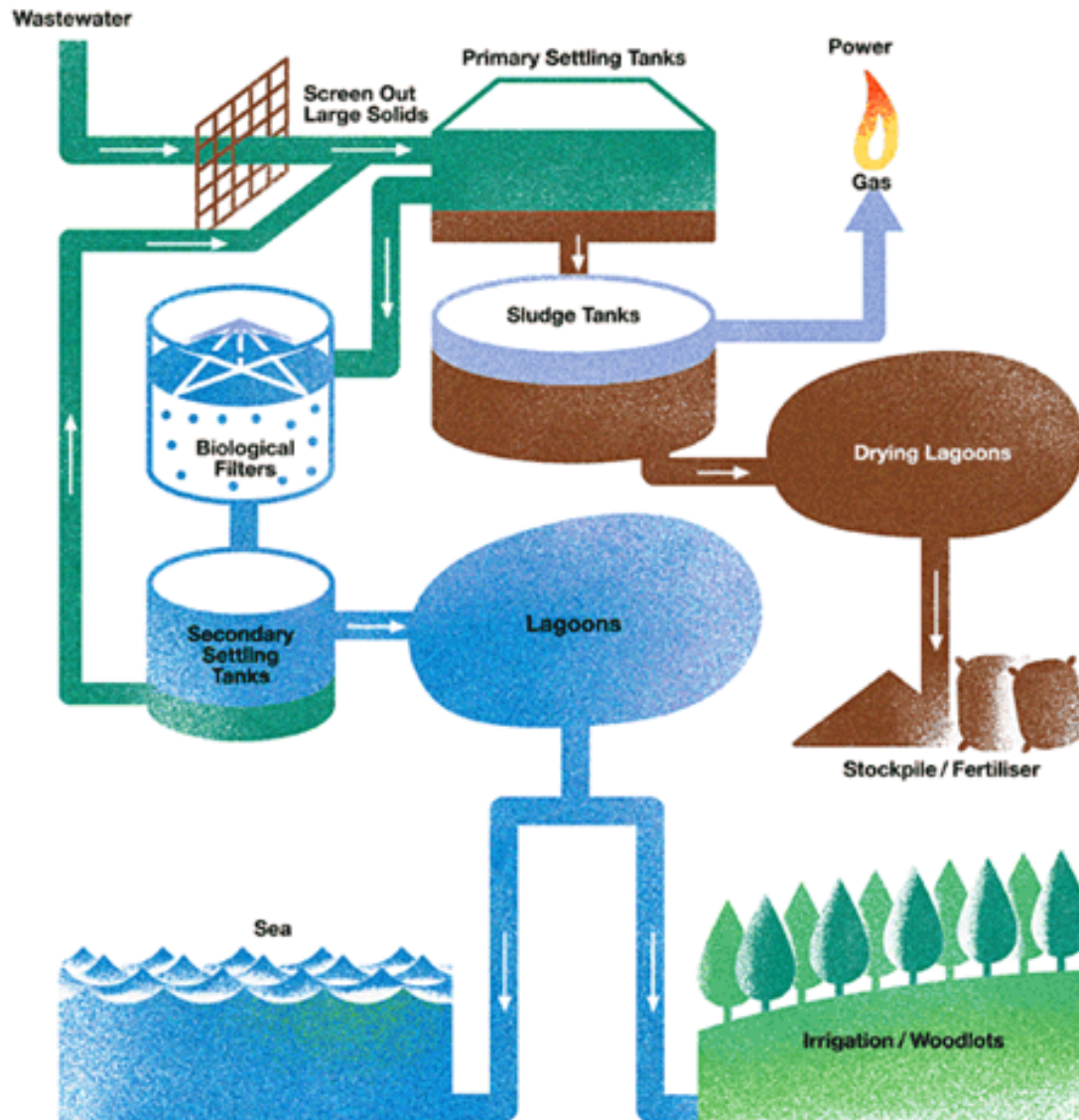



ETP Continuous Type (Only Chemical Treatment)

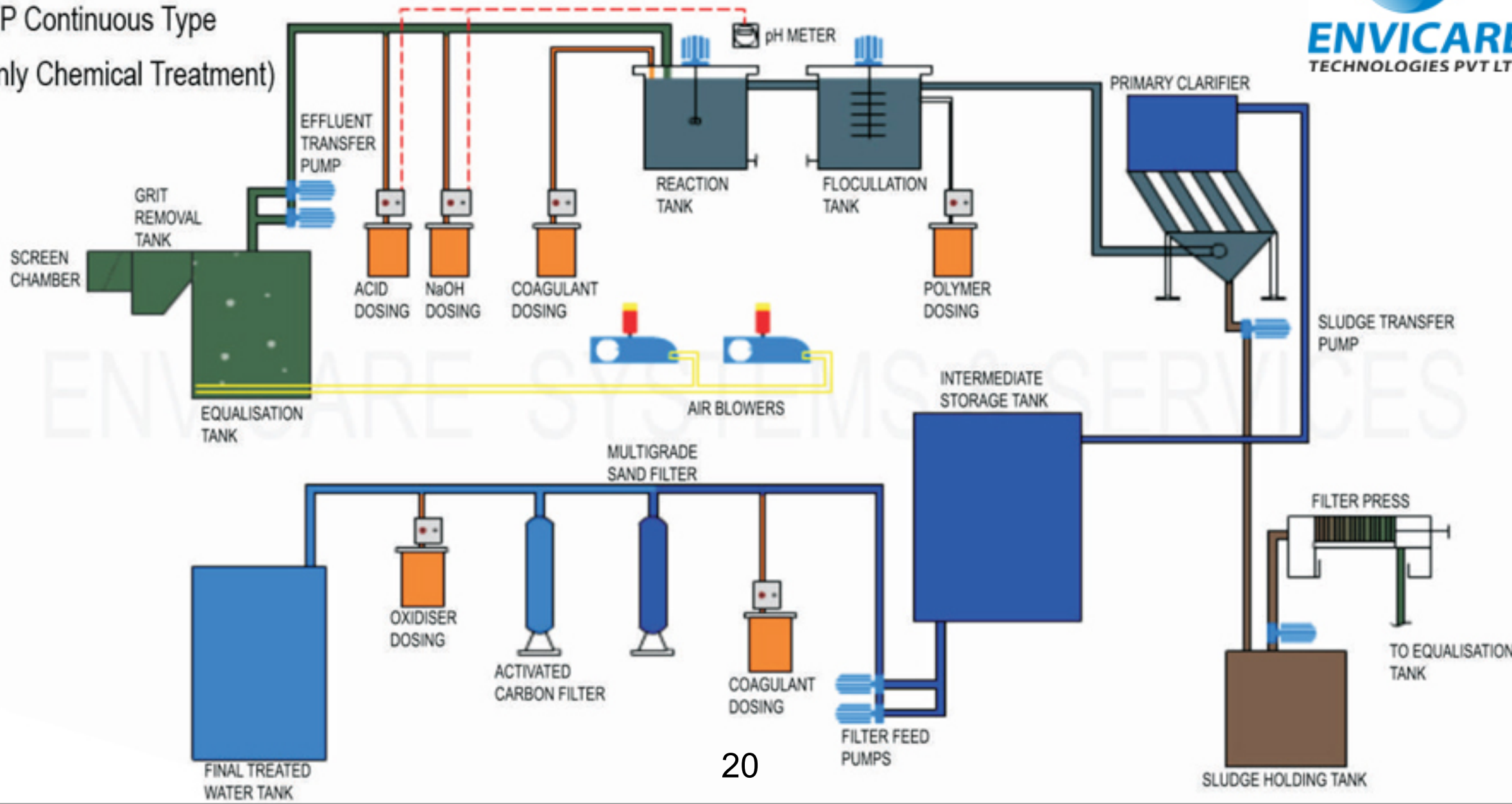

Limitation of different process:

The physico-chemical methods with coagulation-flocculation can treat effectively the color and BOD in the influent. However, the disadvantage of this method are the high chemical cost, large amount of highly toxic physico-chemical sludge and cannot satisfy national effluent quality standard (NEQS).

Biological treatment is the most economic and eco-friendly process due to least running cost, no hazardous chemicals are required and very low non-toxic sludge are produced. In this method waste water is treated by microorganisms mainly bacteria.

Combination of physico-chemical and biological method is the most efficient method where the bacteria or micro organism failed to treat (in high temperature and non biodegradable compound) the effluent. But it has the most running cost.

Wastewater treatment with oxidants like chlorine is now practicing in Bangladesh. Chlorine can react with natural organic compounds which can produce dangerous compounds known as disinfection byproducts (DBPs). Wastewater treatment with Chlorine may produce Aromatic organic halides (AOX), Trihalomethanes (THMs), Dioxins. Skin diseases and inhalation problems can be occurred. Most of the time this process cannot maintain discharge standard.

Sludge characteristics:

Parameter	Physic-chemical	Biological	Combined bio-chemical	Chlorination
Sludge quantity	2-5 kg/m ³	300-4000 kg/m ³	2-5 kg/m ³	Negligible
Sludge toxicity	Highly toxic	Non-toxic	toxic	--
Sludge disposal	Severe	Slight	Medium	--
Sludge disposal cost	High	Very low	High	--
Sludge utilization	Brick	Fertilizer , brick	Brick	--