

Level 1 Term 1

Level 1 Term 2

ARCH 109

BUILDING & FINISH MATERIALS

CONTENTS

Building Brick Clays

Chief Constituents

Harmful Constituents of Brick Clays

Classification of brick & clay products

Manufacture of clay bricks

Requirement of good brickwork

- Strength & durability

- Characteristics of good bricks

- Heavy duty burnt clay bricks or engineering building bricks

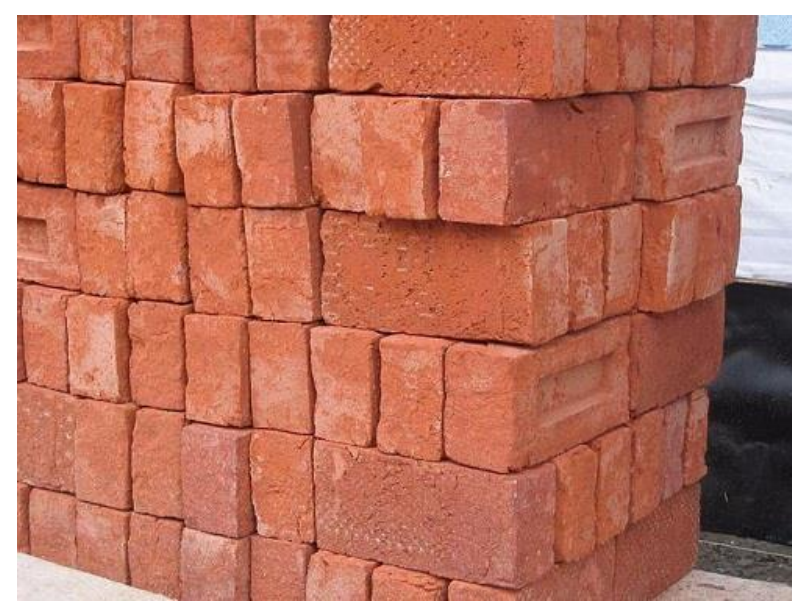

Clay Products

2 main category

i) **CLAY STRUCTURAL MATERIALS**

Bricks

ii) **CERAMIC MATERIALS**

tiles, paving bricks, stoneware,
tera cotta, pottery, enamels, porcelain
etc.

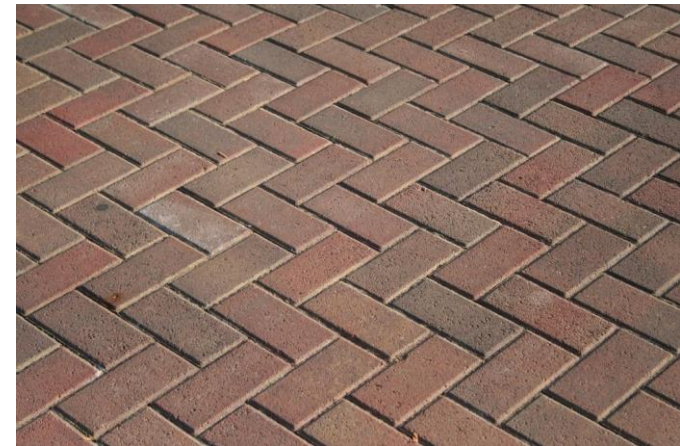
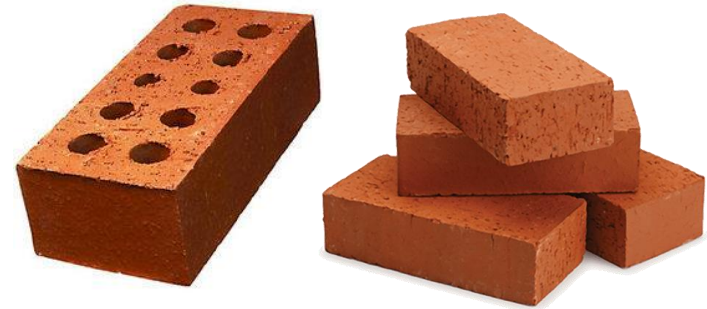

Brick Clay Constituents

- **Clay Substance Alumina & Silicates**

Orthoclase feldspar ($K_2O \cdot Al_2O_3 \cdot 6SiO_2$)

- **Uncombined Silica or Free Sand**

Quartz, SiO_2

- **Lime, Magnesia & Iron**

Hornblende, pyroxenes and lime feldspar

- **Other Minerals**

Na, Mn, Cr

Brick Sizes

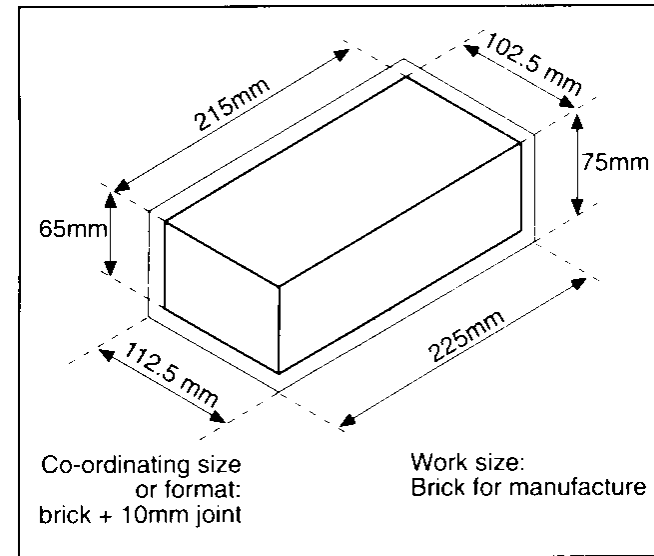
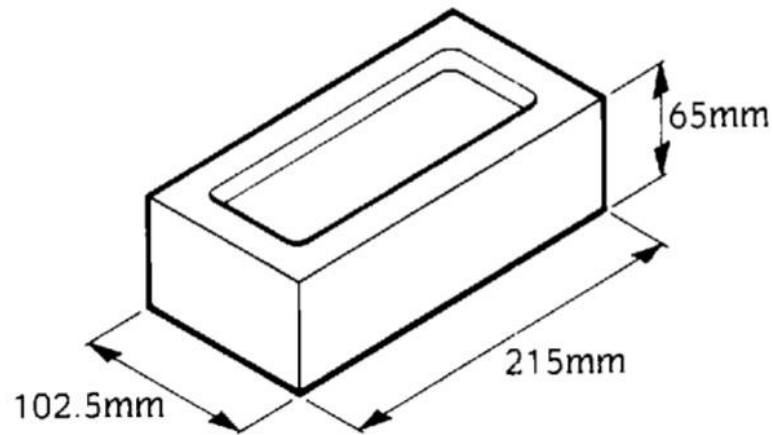

- The length, width and height of a brick are: Length of brick = 2 × width of brick + thickness of mortar
- standard brick: **215 mm x 102.5 mm x 65 mm (length x depth x height)**
- Clay bricks are commonly used since these are economical and easily available

Harmful Constituents of Brick Clays

☐ PEBBLES OF STONE

- Do **not allow** clay to mix properly
- **Harmful** to the uniformity of brick
- **Porosity** in bricks

☐ ALKALIES

- **Lowering fusion point**
- **Fuse, twist and warp** of brick during burning
- Alkaline salts absorb moisture thus **create dampness**
- **Greyish white deposit** spoils the appearance, known as **efflorescence**

efflorescence

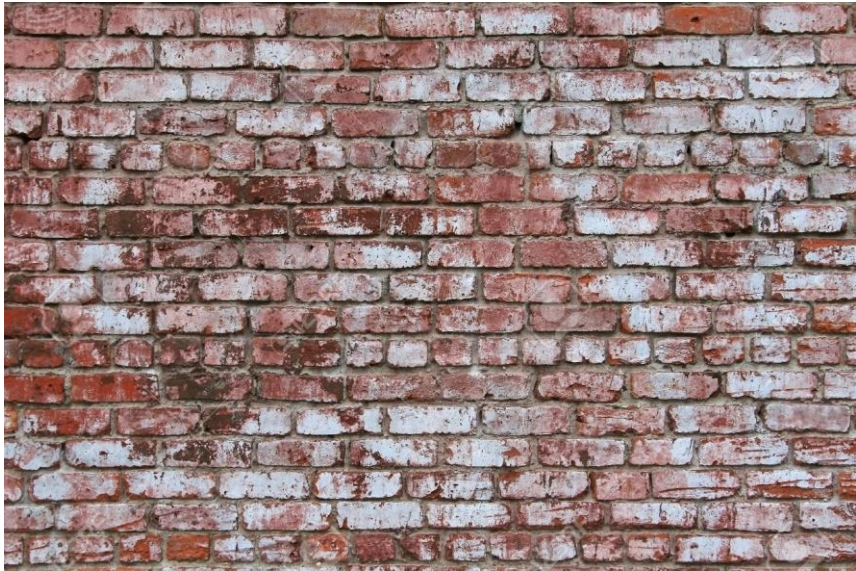

Harmful Constituents of Brick Clays

☐ LIMESTONE & KANKAR NODULES

- **CaO – anhydrous body**, gets hydrated when contact with water
- Increase in bulk (2 to 3 times), causes to **split and crumble** to pieces

☐ IRON PYRITES

- **Decompose and oxidize** in the brick
- **Crystalize and split** into pieces

☐ VEGETATION & ORGANIC MATTER

- **Should be completely burnt** if present, other wise porous brick is formed



Types of Bricks and Clay Products (based on uses)

Building Brick face bricks- pressed and repressed, wide range of shapes, bullnose bricks, coping bricks, sector bricks, chequered bricks

Paving Brick paving purpose

Fire Bricks withstand furnace temperature, silica, magnesia, alumina brick

Building Tiles roofing, walling, flooring tiles

Agricultural or Drain Tiles and Pipes porous, used for drainage purpose

Sewer Pipes non porous, used for sewerage purpose

Terra cotta and Sanitary Ware for sanitary installation and decorative work

Hollow Bricks

- known as **cavity bricks or cellular bricks**
- Lightweight (**one-third of the weight of the normal bricks**)
- **good for insulation** for heat and sound
- used mostly in partition walls where **load-bearing is not required**

Lightweight Bricks

Known as **perforated bricks, air or cored bricks**

30% - 45% perforation area

less load to structure

improved thermal insulation

Engineering Bricks

Offer excellent **load bearing capacity**



5 Common Types of Brick: Classification and Uses



 the balance

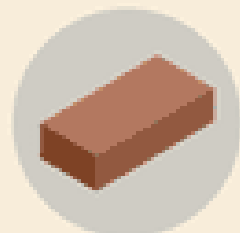

**Common Burnt
Clay Bricks**

Used in general work

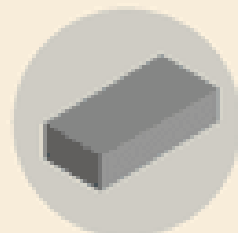

**Sand Lime
Bricks**

Offer excellent strength

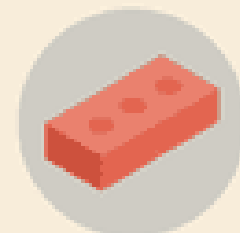

**Engineering
Bricks**

**Offer excellent load
bearing capacity**

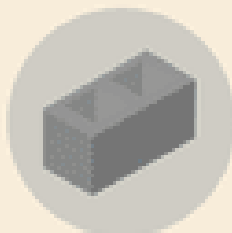

Concrete Bricks

**Provide excellent
aesthetic presence**

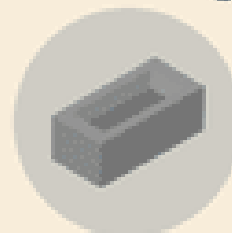

Fly Ash Clay Bricks

**May expand when they come
into contact with moisture**

Manufacture of Clay Bricks

Principal Stages –

- 1. Winning & Preparation of Clay**
- 2. Moulding**
- 3. Drying**
- 4. Burning**
- 5. Annealing**

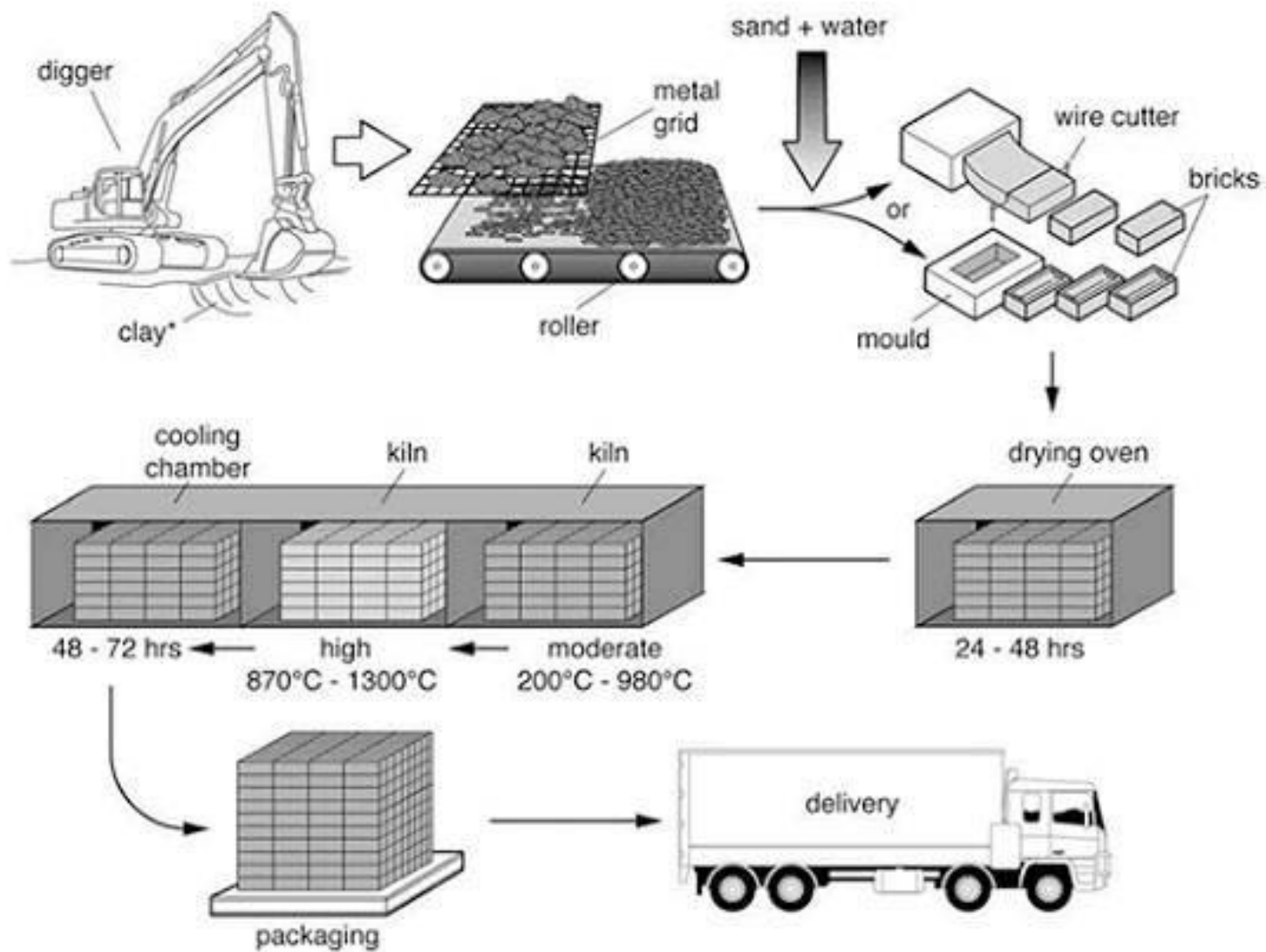

Requirement of Good Brickwork

Strength & Durability

structure should be strong & durable
To withstand load and forces

Tests & Characteristics of Good Bricks

- Shape & size
- Physical properties
- Compressive strength
- Transverse Strength
- Water Absorption
- Presence of Soluble salts
- Weather Resistance
- Fire Resistance
- Expansion of Bricks
- Thermal Conductivity & Sound Insulation

Shape & size

- Standard size **19 x 9x 9 cms**
- **1 cu.m. of brick masonry = 500 Bricks**
- Should be truly rectangular shape, plane faces and sharp edges

Physical properties

- Fine, compact and uniform texture
- Sound hard, well burnt
- **Metallic sound** when struck with hammer or another brick
- **Should not break** when dropped from a height of 1 meter
- **Uniformity of color**
- Free from cracks, fissures, holes, air bubbles, pebbles-stones, lime etc.
- **Weight = 2 gms per cu. cm. or 3 kg per brick**

Compressive Strength

- **35 kg per sq cm** for A grade bricks
- **70 & 140 kg per sq cm** for AA grade bricks

Transverse Strength

- Toughness and ability to resist common failure
- Modulus or rupture of bricks varies from **70 to 210 kg per sq cm** depending on type and quality

Water Absorption

- Represented by percentage of water absorbed by brick for 24 hrs
- Varies with the classes of brick

Porosity and Permeability

Presence of Soluble Salts

- Sulphates of calcium, magnesium, sodium and potassium
- **Safe percentage 0.5 – 2.5**
- Large quantities create dampness and wet condition

Resistance to Weathering

Frost resistance

Chemical action of water

Fire Resistance high resistant to fire

Expansion of Bricks linear expansion of .02 in wetted, excess change might indicate under burnt brick

Thermal expansion of 5 to 8×10^{-6} of length per degree C in temperature

Thermal Conductivity and Sound Insulation

Low thermal conductivity, cool in summer and warm in winter.

Light weight brick - good sound insulator

In the Context of Bangladesh



In the Context of Bangladesh

- Bangladesh is the **fourth largest producer and consumer of bricks in Asia** after China, India, Pakistan and Vietnam, according to various industry studies.
- country produces **25 billion bricks every year**

(Source: <http://www.theindependentbd.com/post/199174>)

- more than **6000 traditional brick kilns** which cater for 99 per cent of the 17 billion pieces of the country's annual brick requirement.
- kilns produce nearly 60 per cent of Dhaka's air pollution, with the rest coming from dust and vehicles (Source: Bangladesh's Department of Environment)

In the Context of Bangladesh

- **CURRENT SCENARIO** : For sometime now, the government's **Housing and Building Research Institute (HBRI)** has been actively involved in conducting experiments on a diverse range of **alternatives to traditional kiln bricks**.
- 15 organised alternative brick (AB) manufacturing companies in the country at present, of which top 5 companies are controlling most of the market share

Source: <https://thefinancialexpress.com.bd/views/views/promoting-non-fired-brick-production-1512745996>

- meeting this demand requires excavating 60 million tonnes of topsoil, **causing dust pollution and degrading the ground**.

(Mohammad Abu Sadeque, head of the Housing and Building Research Institute (HBRI))

In the Context of Bangladesh

- In case of alternative bricks, **close to 55 per cent of the total cost** of a standard alternative brick goes to **raw material sourcing and transportation of raw material** from the source to factory reflecting the crucial role that raw materials play in this industry.
- **Sylhet Sand, pea gravel, stone dust, stone chips, cement and water** are the required raw materials which are primarily collected from domestic sources. Some of the manufacturers purchase their raw materials from **India (Tripura), Vietnam, Oman** etc.
- The products include bricks made of a compressed composite material consisting of river mud and cement. The bricks do not require firing in a kiln, but simply harden in the sun.
- lighter than traditional ones, making them easier and cheaper to transport

Benefits

- reducing construction cost by around 20-25 per cent
- provides positive environmental impact, structural integrity and high durability
- resistant to temperature which makes them less susceptible to temperature fluctuations
- **lower heating and cooling bills by up to 25 per cent(hollow blocks)**
- Cement is one of the most durable materials on earth which is the main component of the brick, therefore high capacity to protect against high winds, fire and earthquakes
- do not absorb moisture or water, making the buildings safe from rotting, wall warping, termites, molds and rusting.



Facts

- Each piece of hollow block costs **Tk 30-Tk 35**. A piece of hollow block is 4.5 times bigger than a traditional brick. So it will reduce the construction cost(according to HBRI)
- Concord uses hollow block in all the buildings which we build. So far, **such blocks have been in 500 buildings of Concord**



Hybrid Hoffman Kiln Technology- a green solution

- In 2008, the Bangladesh Hybrid Hoffman Kiln (HHK) project began paving the way for cleaner brick technologies, improved labor conditions and better lives for the workers.
- Originally developed in Germany, the HHK technology was imported to Bangladesh after improvement by the Chinese and now has been redesigned to suit local soil conditions, humidity levels and climate. It deploys a mix of pulverized coal and clay to improve the quality and proper burning of the bricks. In addition, the waste heat from the kiln is collected and re-used to dry the green bricks before they enter the kiln. Due to those innovations, HHKs use only half the amount of coal compared to fixed chimney kilns and trap coal particles inside the brick to prevent them from becoming air-borne fly ash.

- an HHK kiln can produce 15 million bricks a year -- compared to four million by a fixed chimney kiln — while reducing pollution by 50 percent
- **HHK technology costs up to 15 times more to build than traditional kilns.**